



Extremely Low Power/Voltage CMOS SRAM 128K X 8 bit

BS62XV1024

■ FEATURES

- Extremely low operation voltage : 1.2V ~ 2.4V
- Extremely low power consumption :
 - Vcc = 1.5V 10mA (Max.) write current
0.5mA (Max.) read current
0.005uA (Typ.) CMOS standby current
 - Vcc = 2.2V 15mA (Max.) write current
0.8mA (Max.) read current
0.01uA (Typ.) CMOS standby current
- High speed access time :
-25 250ns (Max.)
- Input levels are CMOS-compatible
- Automatic power down when chip is deselected
- Three state outputs
- Fully static operation
- Data retention supply voltage as low as 1.2V
- Easy expansion with CE2, CE1, and OE options
- All I/O pins are 3.3V tolerant

■ DESCRIPTION

The BS62XV1024 is a high performance, extremely low power CMOS Static Random Access Memory organized as 131,072 words by 8 bits and operates from an extremely low range of 1.2V to 2.4V supply voltage.

Advanced CMOS technology and circuit techniques provide both high speed and low power features with a typical CMOS standby current of 0.005uA and maximum access time of 250ns in 1.5V operation.

Easy memory expansion is provided by an active LOW chip enable (CE1), an active HIGH chip enable (CE2), and active LOW output enable (OE) and three-state output drivers.

The BS62XV1024 has an automatic power down feature, reducing the power consumption significantly when chip is deselected.

The BS62XV1024 is available in the JEDEC standard 32 pin 525mil Plastic SOP, 8mmx13.4mm STSOP, and 8mmx20mm TSOP.

■ PRODUCT FAMILY

PRODUCT FAMILY	OPERATING TEMPERATURE	Vcc RANGE	SPEED (ns)	POWER DISSIPATION				PKG TYPE
				STANDBY (Iccsb1, Max)		Operating (Icc, Max)		
				Vcc= 2.2V	Vcc= 1.5V	Vcc= 2.2V	Vcc= 1.5V	
BS62XV1024SC	+0°C to +70°C	1.2V ~ 2.4V	250	0.3uA	0.2uA	15mA	10mA	SOP-32
BS62XV1024TC								TSOP-32
BS62XV1024STC								STSOP-32
BS62XV1024SI	-40°C to +85°C	1.2V ~ 2.4V	250	1uA	0.8uA	15mA	10mA	SOP-32
BS62XV1024TI								TSOP-32
BS62XV1024STI								STSOP-32

■ PIN CONFIGURATIONS

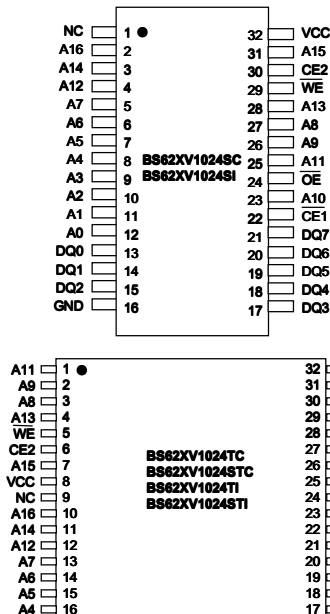

■ BLOCK DIAGRAM

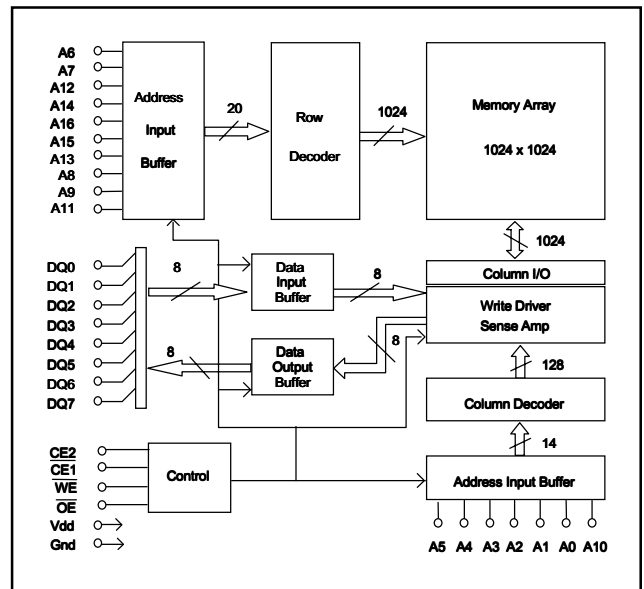

Brilliance Semiconductor Inc. reserves the right to modify document contents without notice.

■ PIN DESCRIPTIONS

Name	Function
A0-A16 Address Input	These 17 address input select one of the 131,072 x 8-bit words in the RAM
$\overline{CE1}$ Chip Enable 1 Input $\overline{CE2}$ Chip Enable 2 Input	$\overline{CE1}$ is active LOW and $\overline{CE2}$ is active HIGH. Both chip enables must be active to read from or write to the device. If either chip enable is not active, the device is deselected and is in a standby power mode. The DQ pins will be in the high impedance state when the device is deselected.
\overline{WE} Write Enable Input	The write enable input is active LOW and controls read and write operations. With the chip selected, when \overline{WE} is HIGH and \overline{OE} is LOW, output data will be present on the DQ pins; when \overline{WE} is LOW, the data present on the DQ pins will be written into the selected memory location.
\overline{OE} Output Enable Input	The output enable input is active LOW. If the output enable is active while the chip is selected and the write enable is inactive, data will be present on the DQ pins and they will be enabled. The DQ pins will be in the high impedance state when \overline{OE} is inactive.
DQ0 – DQ7 Data Input/Output Ports	These 8 bi-directional ports are used to read data from or write data into the RAM.
Vcc	Power Supply
Gnd	Ground

■ TRUTH TABLE

MODE	\overline{WE}	$\overline{CE1}$	$\overline{CE2}$	\overline{OE}	I/O OPERATION	Vcc CURRENT
Not selected (Power Down)	X	H	X	X	High Z	I_{CCSB}, I_{CCSB1}
	X	X	L	X		
Output Disabled	H	L	H	H	High Z	I_{CC}
Read	H	L	H	L	DOUT	I_{CC}
Write	L	L	H	X	DIN	I_{CC}

■ ABSOLUTE MAXIMUM RATINGS⁽¹⁾

SYMBOL	PARAMETER	RATING	UNITS
VTERM	Terminal Voltage with Respect to GND	-0.5 to +6.0	V
TBIAS	Temperature Under Bias	-40 to +125	°C
TSTG	Storage Temperature	-60 to +150	°C
PT	Power Dissipation	1.0	W
IOUT	DC Output Current	20	mA

1. Stresses greater than those listed under ABSOLUTE MAXIMUM RATINGS may cause permanent damage to the device. This is a stress rating only and functional operation of the device at these or any other conditions above those indicated in the operational sections of this specification is not implied. Exposure to absolute maximum rating conditions for extended periods may affect reliability.

■ OPERATING RANGE

RANGE	AMBIENT TEMPERATURE	Vcc
Commercial	0°C to +70°C	1.2V ~ 2.4V
Industrial	-40°C to +70°C	1.2V ~ 2.4V

■ CAPACITANCE ⁽¹⁾ (TA = 25°C, f = 1.0 MHz)

SYMBOL	PARAMETER	CONDITIONS	MAX.	UNIT
CIN	Input Capacitance	VIN=0V	6	pF
CDQ	Input/Output Capacitance	V/I=0V	8	pF

1. This parameter is guaranteed and not tested.

■ DC ELECTRICAL CHARACTERISTICS (TA = 0 to + 70°C)

PARAMETER NAME	PARAMETER	TEST CONDITIONS	MIN.	TYP. (1)	MAX.	UNITS	
V _{IL}	Guaranteed Input Low Voltage ⁽²⁾		-0.5	--	0.3V _{cc}	V	
V _{IH}	Guaranteed Input High Voltage ⁽²⁾		0.7V _{cc}	--	V _{cc} +0.2	V	
I _{IL}	Input Leakage Current	V _{cc} = Max, V _{IN} = 0V to V _{cc}	--	--	1	μA	
I _{OL}	Output Leakage Current	V _{cc} = Max, $\overline{CE1} = V_{IH}$, CE2 = V _L , or $\overline{OE} = V_{IH}$, V _{IO} = 0V to V _{cc}	--	--	1	μA	
V _{OL}	Output Low Voltage	V _{cc} = Max, I _{OL} = 1mA	--	--	0.3	V	
V _{OH}	Output High Voltage	V _{cc} = Min, I _{OH} = -0.5mA	1.2	--	--	V	
I _{CC}	Operating Power Supply Current	$\overline{CE1} = V_{L}$, or CE2 = V _{IH} , I _{OL} = 0mA, F = Fmax ⁽³⁾	V _{cc} =1.5V	--	--	10	mA
			V _{cc} =2.2V	--	--	15	
I _{CCSB}	Standby Power Supply Current	$\overline{CE1} = V_{IH}$, or CE2 = V _L , I _{OL} = 0mA, F = Fmax ⁽³⁾	V _{cc} =1.5V	--	--	0.5	mA
			V _{cc} =2.2V	--	--	1	
I _{CCSB1}	Power Down Supply Current	$\overline{CE1} \geq V_{cc}-0.2V$, CE2 ≤ 0.2V, V _{IN} ≥ V _{cc} -0.2V or V _{IN} ≤ 0.2V	V _{cc} =1.5V	--	0.005	0.2	μA
			V _{cc} =2.2V	--	0.01	0.3	

1. Typical characteristics are at TA = 25°C.

2. These are absolute values with respect to device ground and all overshoots due to system or tester noise are included.

3. Fmax = 1/t_{RC}.

■ DATA RETENTION CHARACTERISTICS (TA = 0 to + 70°C)

SYMBOL	PARAMETER	TEST CONDITIONS	MIN.	TYP. (1)	MAX.	UNITS
V _{DR}	V _{cc} for Data Retention	$\overline{CE1} \geq V_{cc} - 0.2V$, CE2 ≤ 0.2V, V _{IN} ≥ V _{cc} - 0.2V or V_{IN} ≤ 0.2V}	1.2	--	--	V
I _{CCDR}	Data Retention Current	$\overline{CE1} \geq V_{cc} - 0.2V$, CE2 ≤ 0.2V, V _{IN} ≥ V _{cc} - 0.2V or V_{IN} ≤ 0.2V}	--	0.005	0.1	μA
t _{CDR}	Chip Deselect to Data Retention Time	See Retention Waveform	0	--	--	ns
t _R	Operation Recovery Time		T _{RC} ⁽²⁾	--	--	ns

1. V_{cc} = 1.5V, T_A = + 25°C



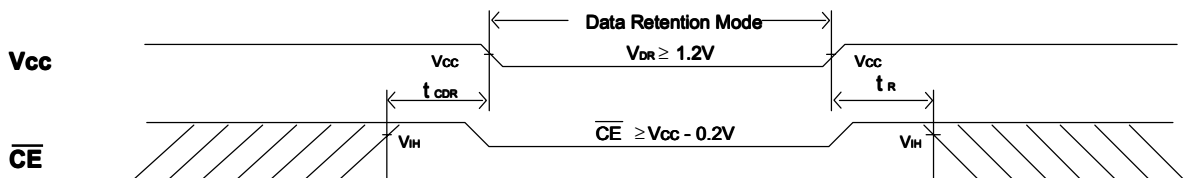
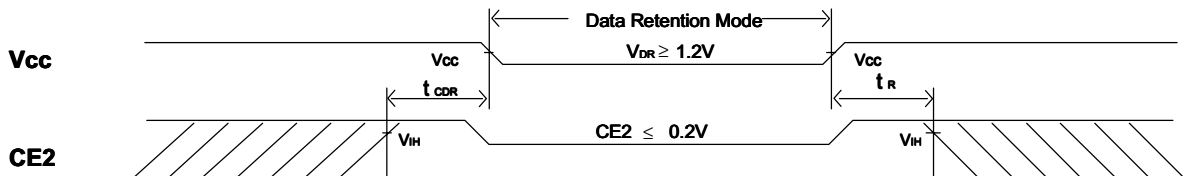

2. t_{RC} = Read Cycle Time

■ LOW V_{CC} DATA RETENTION WAVEFORM (1) ($\overline{CE1}$ Controlled)

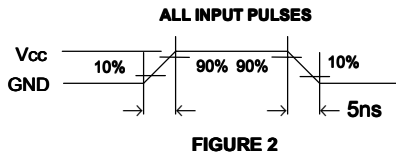
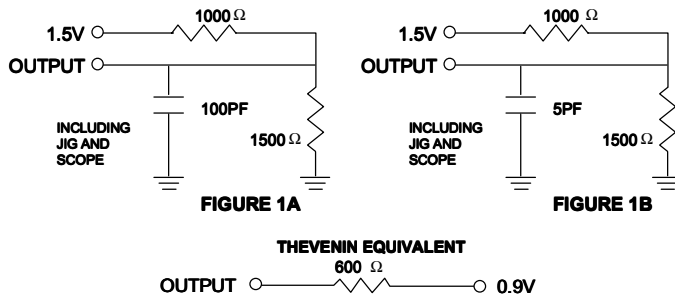
■ LOW V_{CC} DATA RETENTION WAVEFORM (2) (CE2 Controlled)

■ AC TEST CONDITIONS

Input Pulse Levels	V _{cc} /0V
Input Rise and Fall Times	5ns
Input and Output Timing Reference Level	0.5V _{cc}

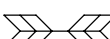
■ AC TEST LOADS AND WAVEFORMS

■ KEY TO SWITCHING WAVEFORMS

WAVEFORM	INPUTS	OUTPUTS
	MUST BE STEADY	MUST BE STEADY
	MAY CHANGE FROM H TO L	WILL BE CHANGE FROM H TO L
	MAY CHANGE FROM L TO H	WILL BE CHANGE FROM L TO H
	DON'T CARE: ANY CHANGE PERMITTED	CHANGE: STATE UNKNOWN
	DOES NOT APPLY	CENTER LINE IS HIGH IMPEDANCE "OFF" STATE

■ AC ELECTRICAL CHARACTERISTICS (over the operating range)
READ CYCLE

JEDEC PARAMETER NAME	PARAMETER NAME	DESCRIPTION	BS62XV1024-25			UNIT
			MIN.	TYP.	MAX.	
t _{AVAX}	t _{RC}	Read Cycle Time	250	--	--	ns
t _{AVQV}	t _{AA}	Address Access Time	--	--	250	ns
t _{E1LQV}	t _{ACS1}	Chip Select Access Time (CE1)	--	--	250	ns
t _{E2HOV}	t _{ACS2}	Chip Select Access Time (CE2)	--	--	250	ns
t _{GLQV}	t _{OE}	Output Enable to Output Valid	--	--	150	ns
t _{E1LQX}	t _{CLZ1}	Chip Select to Output Low Z (CE1)	15	--	--	ns
t _{E2HOX}	t _{CLZ2}	Chip Select to Output Low Z (CE2)	10	--	--	ns
t _{GLQX}	t _{OLZ}	Output Enable to Output in Low Z	10	--	--	ns
t _{E1HQZ}	t _{CHZ1}	Chip Deselect to Output in High Z (CE1)	0	--	40	ns
t _{E2HQZ}	t _{CHZ1}	Chip Deselect to Output in High Z (CE2)			40	
t _{GHQZ}	t _{OHZ}	Output Disable to Output in High Z	0	--	35	ns
t _{AXOX}	t _{OH}	Output Disable to Output Address Change	10	--	--	ns

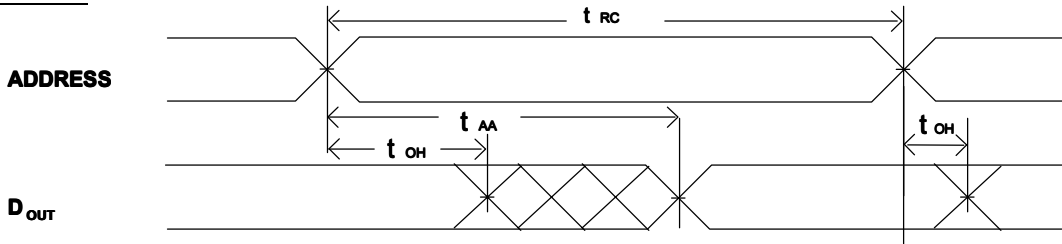
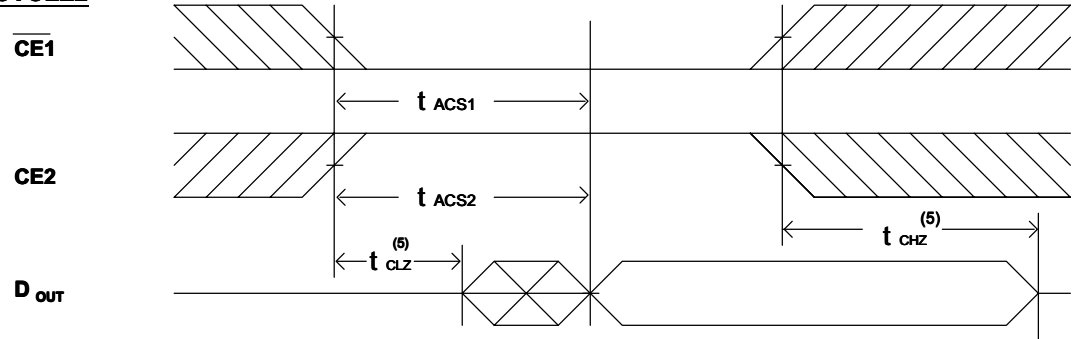
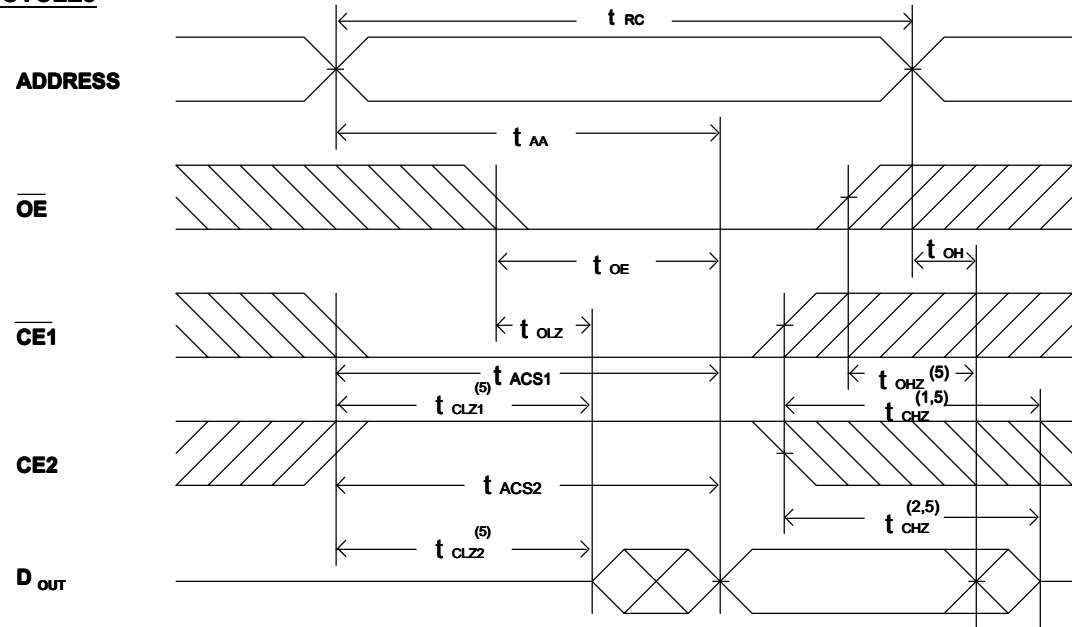
1. Typical characteristics are at V_{cc} = 1.5V, T_A = 25°C.

■ SWITCHING WAVEFORMS (READ CYCLE)
READ CYCLE1 (1,2,4)

READ CYCLE2 (1,3,4)

READ CYCLE3 (1,4)

NOTES:

1. WE is high for read Cycle.
2. Device is continuously selected when $\overline{CE1} = V_{IL}$ and $\overline{CE2} = V_{IH}$.
3. Address valid prior to or coincident with $\overline{CE1}$ transition low and/or $\overline{CE2}$ transition high.
4. $\overline{OE} = V_{IL}$.
5. Transition is measured $\pm 500\text{mV}$ from steady state with $C_L = 5\text{pF}$ as shown in Figure 1B. The parameter is guaranteed but not 100% tested.

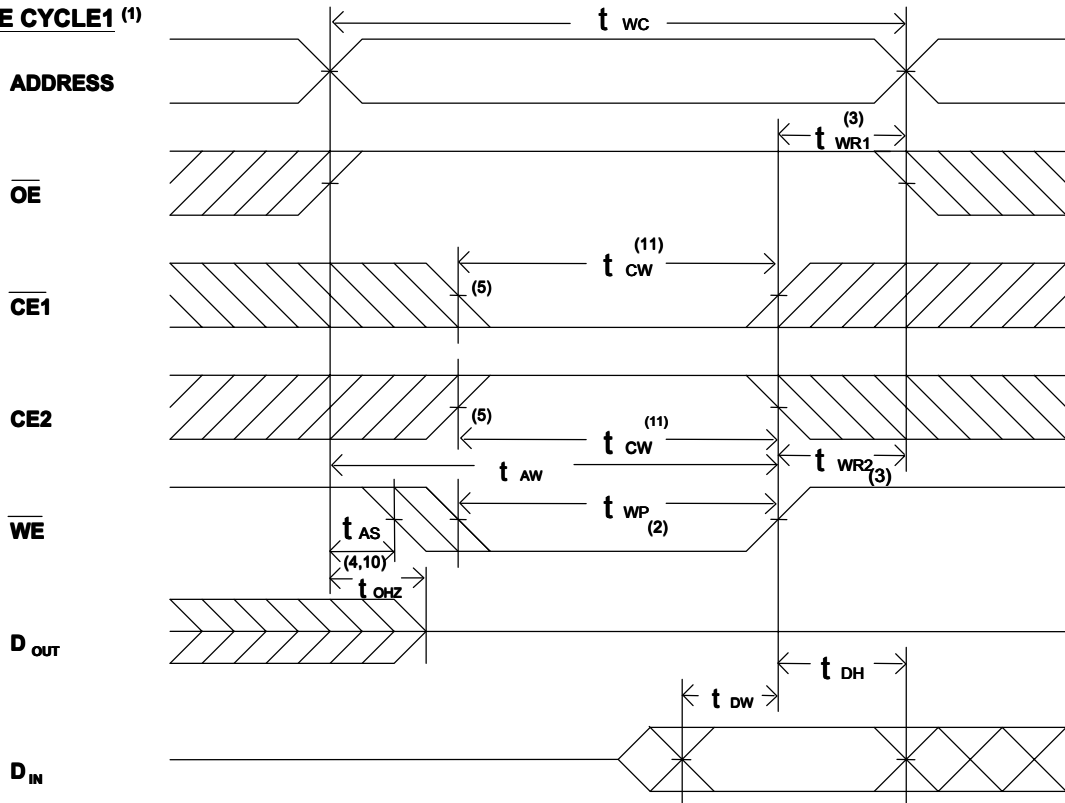
■ AC ELECTRICAL CHARACTERISTICS (over the operating range)
WRITE CYCLE

JEDEC PARAMETER NAME	PARAMETER NAME	DESCRIPTION	BS62XV1024-25			UNIT
			MIN.	TYP.	MAX.	
t_{AVAX}	t_{WC}	Write Cycle Time	250	--	--	ns
t_{E1LWH}	t_{CW}	Chip Select to End of Write	250	--	--	ns
t_{AVWL}	t_{AS}	Address Set up Time	0	--	--	ns
t_{AVWH}	t_{AW}	Address Valid to End of Write	250	--	--	ns
t_{WLWH}	t_{WP}	Write Pulse Width	150	--	--	ns
t_{WHAX}	t_{WR1}	Write Recovery Time ($\overline{CE1}$, \overline{WE})	0	--	--	ns
t_{E2LAX}	t_{WR2}	Write Recovery Time (CE2)	0	--	--	ns
t_{WLOZ}	t_{WHZ}	Write to Output in High Z	--	--	40	ns
t_{DVWH}	t_{DW}	Data to Write Time Overlap	100	--	--	ns
t_{WHDX}	t_{DH}	Data Hold from Write Time	0	--	--	ns
t_{GHOZ}	t_{OHZ}	Output Disable to Output in High Z	0	--	40	ns
t_{WHQX}	t_{OW}	End of Write to Output Active	5	--	--	ns

1. Typical characteristics are at $V_{CC} = 1.5V$, $T_A = 25^\circ C$.

■ SWITCHING WAVEFORMS (WRITE CYCLE)
WRITE CYCLE1⁽¹⁾

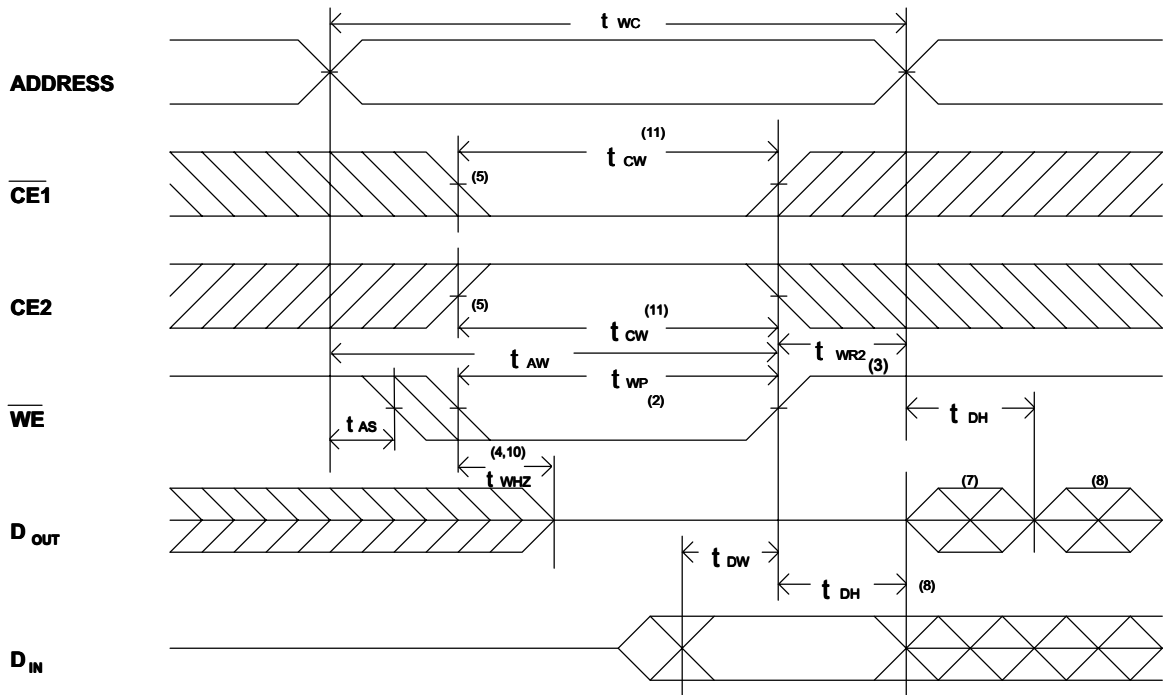
WRITE CYCLE2 (1,6)

NOTES:

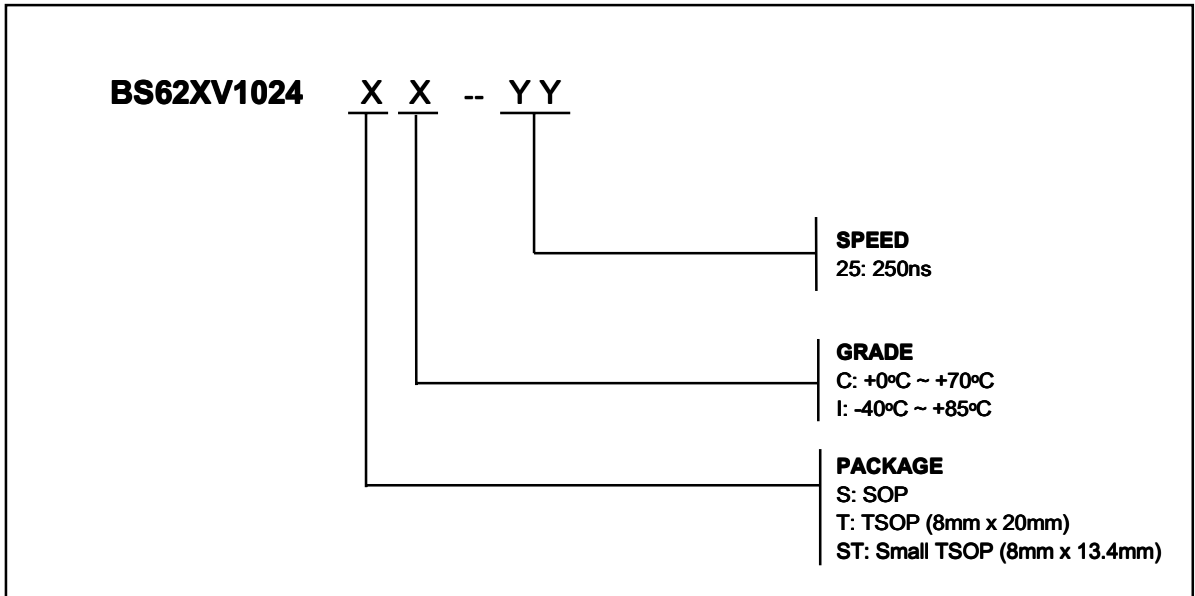
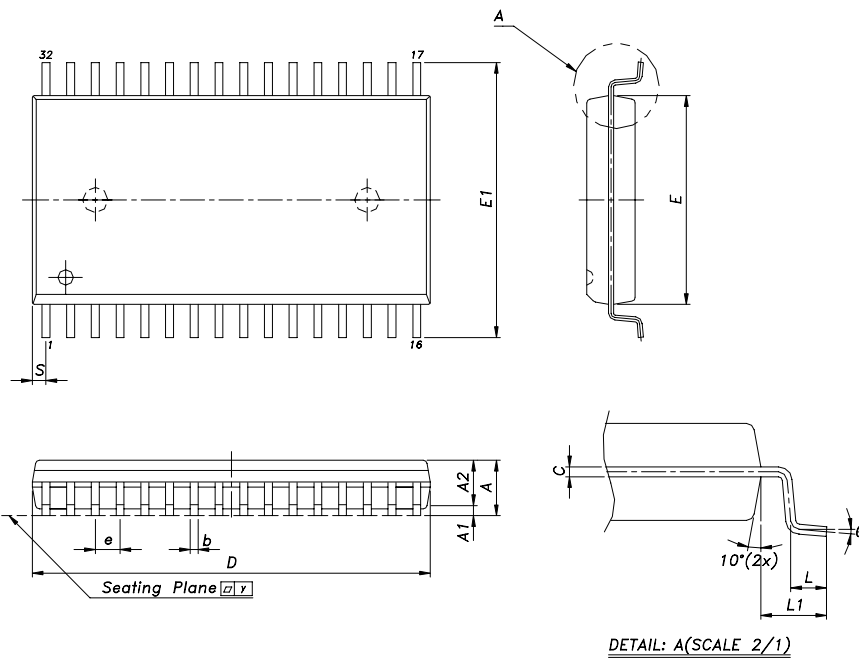
1. \overline{WE} must be high during address transitions.
2. The internal write time of the memory is defined by the overlap of $\overline{CE1}$ and $\overline{CE2}$ active and \overline{WE} low. All signals must be active to initiate a write and any one signal can terminate a write by going inactive. The data input setup and hold timing should be referenced to the second transition edge of the signal that terminates the write.
3. t_{WR} is measured from the earlier of $\overline{CE1}$ or \overline{WE} going high or $\overline{CE2}$ going low at the end of write cycle.
4. During this period, DQ pins are in the output state so that the input signals of opposite phase to the outputs must not be applied.
5. If the $\overline{CE1}$ low transition or the $\overline{CE2}$ high transition occurs simultaneously with the \overline{WE} low transitions or after the \overline{WE} transition, output remain in a high impedance state.
6. \overline{OE} is continuously low ($\overline{OE} = V_{IL}$).
7. D_{out} is the same phase of write data of this write cycle.
8. D_{out} is the read data of next address.
9. If $\overline{CE1}$ is low and $\overline{CE2}$ is high during this period, DQ pins are in the output state. Then the data input signals of opposite phase to the outputs must not be applied to them.
10. Transition is measured $\pm 500mV$ from steady state with $C_L = 5pF$ as shown in Figure 1B. The parameter is guaranteed but not 100% tested.
11. t_{cw} is measured from the later of $\overline{CE1}$ going low or $\overline{CE2}$ going high to the end of write.

ORDERING INFORMATION

PACKAGE DIMENSIONS

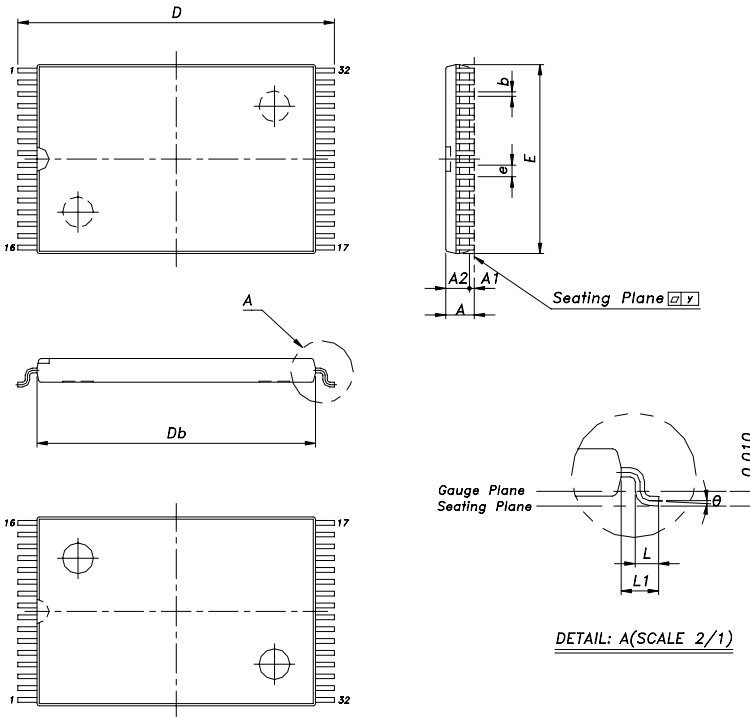
UNIT SYMBOL	INCH(BASE)	MM(REF.)
A	0.118(MAX)	2.997(MAX)
A1	0.004(MIN)	0.102(MIN)
A2	0.104±0.004	2.642±0.102
b	0.016(TYP)	0.406(TYP)
c	0.008(TYP)	0.203(TYP)
D	0.805±0.005	20.447±0.127
E	0.445±0.005	11.303±0.127
E1	0.556±0.012	14.122±0.305
e	0.050(TYP)	1.270(TYP)
L	0.031±0.008	0.787±0.203
L1	0.055±0.008	1.397±0.203
S	0.0275(TYP)	0.6985(TYP)
y	0.004(MAX)	0.102(MAX)
θ	0°-10°	0°-10°

SOP-32

■ PACKAGE DIMENSIONS (continued)

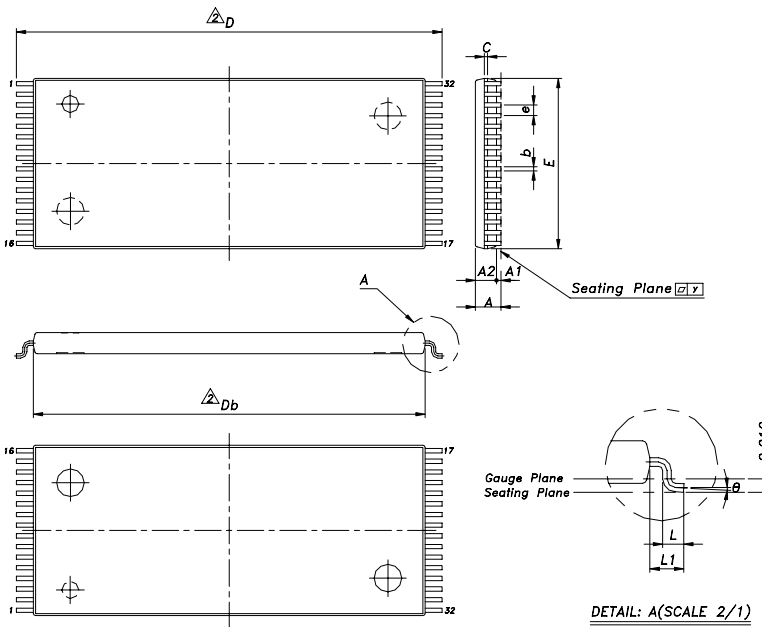
UNIT SYMBOL	INCH(BASE)	MM(REF.)
A	0.047(MAX)	1.20(MAX)
A1	0.004±0.002	0.10±0.05
A2	0.039±0.002	1.00±0.05
b	0.008(TYP)	0.20(TYP)
C	0.006(TYP)	0.15(TYP)
Db	0.465±0.004	11.80±0.10
E	0.315±0.004	8.00±0.10
e	0.020(TYP)	0.50(TYP)
D	0.528±0.008	13.40±0.20
L	0.020±0.004	0.50±0.10
L1	0.0315±0.004	0.80±0.10
y	0.004(MAX)	0.102(MAX)
θ	0°-5°	0°-5°

STSOP-32

UNIT SYMBOL	INCH(BASE)	MM(REF.)
A	0.047(MAX)	1.20(MAX)
A1	0.004±0.002	0.10±0.05
A2	0.039±0.002	1.00±0.05
b	0.008(TYP)	0.20(TYP)
C	0.006(TYP)	0.15(TYP)
Db	0.724±0.004	18.40±0.10
E	0.315±0.004	8.00±0.10
e	0.020(TYP)	0.50(TYP)
D	0.787±0.008	20.00±0.20
L1	0.0315±0.004	0.80±0.10
y	0.004(MAX)	0.102(MAX)
θ	0°-5°	0°-5°

(Option 1)

L	0.020±0.004	0.50±0.10
---	-------------	-----------

(Option 2)

L	0.024±0.004	0.60±0.10
---	-------------	-----------

TSOP-32

This page is left blank intentionally.

■ FEATURES

- Ultra low operation voltage : 1.8V ~ 3.6V
- Ultra low power consumption :
 - Vcc = 2.0V 15mA (Max.) write current
 - 0.8mA (Max.) read current
 - 0.01uA (Typ.) CMOS standby current
- Vcc = 3.3V 20mA (Max.) write current
- 1mA (Max.) read current
- 0.02uA (Typ.) CMOS standby current
- High speed access time :
 - 15 150ns (Max.)
- Input levels are CMOS-compatible
- Automatic power down when chip is deselected
- Three state outputs
- Fully static operation
- Data retention supply voltage as low as 1.5V
- Easy expansion with CE2, CE1, and OE options
- All I/O pins are 3.3V tolerant

■ DESCRIPTION

The BS62UV1024 is a high performance, ultra low power CMOS Static Random Access Memory organized as 131,072 words by 8 bits and operates from a ultra low range of 1.8V to 3.6V supply voltage. Advanced CMOS technology and circuit techniques provide both high speed and low power features with a typical CMOS standby current of 0.01uA and maximum access time of 150ns in 2V operation. Easy memory expansion is provided by an active LOW chip enable (CE1), an active HIGH chip enable (CE2), and active LOW output enable (OE) and three-state output drivers. The BS62UV1024 has an automatic power down feature, reducing the power consumption significantly when chip is deselected. The BS62UV1024 is available in the JEDEC standard 32 pin 525mil Plastic SOP, 8mmx13.4mm STSOP, and 8mmx20mm TSOP.

■ PRODUCT FAMILY

PRODUCT FAMILY	OPERATING TEMPERATURE	Vcc RANGE	SPEED (ns)	POWER DISSIPATION				PKG TYPE
				STANDBY (Iccsb1, Max)		Operating (Icc, Max)		
				Vcc= 3.3V	Vcc= 2.0V	Vcc= 3.3V	Vcc= 2.0V	
BS62UV1024SC	+0°C to +70°C	1.8V ~ 3.6V	150	0.5uA	0.3uA	20mA	15mA	SOP-32
BS62UV1024TC								TSOP-32
BS62UV1024STC								STSOP-32
BS62UV1024SI	-40°C to +85°C	1.8V ~ 3.6V	150	1.5uA	1uA	20mA	15mA	SOP-32
BS62UV1024TI								TSOP-32
BS62UV1024STI								STSOP-32

■ PIN CONFIGURATIONS

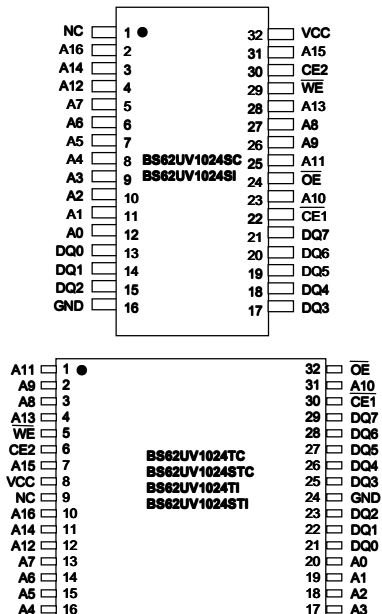

■ BLOCK DIAGRAM

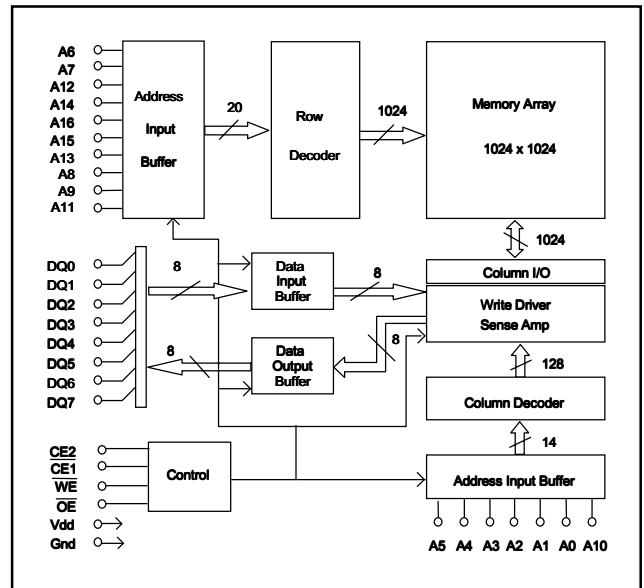

■ PIN DESCRIPTIONS

Name	Function
A0-A16 Address Input	These 17 address input select one of the 131,072 x 8-bit words in the RAM
$\overline{CE1}$ Chip Enable 1 Input $\overline{CE2}$ Chip Enable 2 Input	$\overline{CE1}$ is active LOW and $\overline{CE2}$ is active HIGH. Both chip enables must be active to read from or write to the device. If either chip enable is not active, the device is deselected and is in a standby power mode. The DQ pins will be in the high impedance state when the device is deselected.
\overline{WE} Write Enable Input	The write enable input is active LOW and controls read and write operations. With the chip selected, when \overline{WE} is HIGH and \overline{OE} is LOW, output data will be present on the DQ pins; when \overline{WE} is LOW, the data present on the DQ pins will be written into the selected memory location.
\overline{OE} Output Enable Input	The output enable input is active LOW. If the output enable is active while the chip is selected and the write enable is inactive, data will be present on the DQ pins and they will be enabled. The DQ pins will be in the high impedance state when \overline{OE} is inactive.
DQ0 – DQ7 Data Input/Output Ports	These 8 bi-directional ports are used to read data from or write data into the RAM.
Vcc	Power Supply
Gnd	Ground

■ TRUTH TABLE

MODE	\overline{WE}	$\overline{CE1}$	$\overline{CE2}$	\overline{OE}	I/O OPERATION	Vcc CURRENT
Not selected (Power Down)	X	H	X	X	High Z	I_{CCSB}, I_{CCSB1}
	X	X	L	X		
Output Disabled	H	L	H	H	High Z	I_{CC}
Read	H	L	H	L	DOUT	I_{CC}
Write	L	L	H	X	DIN	I_{CC}

■ ABSOLUTE MAXIMUM RATINGS⁽¹⁾

SYMBOL	PARAMETER	RATING	UNITS
VTERM	Terminal Voltage with Respect to GND	-0.5 to +6.0	V
TBIAS	Temperature Under Bias	-40 to +125	°C
TSTG	Storage Temperature	-60 to +150	°C
PT	Power Dissipation	1.0	W
IOUT	DC Output Current	20	mA

1. Stresses greater than those listed under ABSOLUTE MAXIMUM RATINGS may cause permanent damage to the device. This is a stress rating only and functional operation of the device at these or any other conditions above those indicated in the operational sections of this specification is not implied. Exposure to absolute maximum rating conditions for extended periods may affect reliability.

■ OPERATING RANGE

RANGE	AMBIENT TEMPERATURE	Vcc
Commercial	0°C to +70°C	1.8V ~ 3.6V
Industrial	-40°C to +70°C	1.8V ~ 3.6V

■ CAPACITANCE ⁽¹⁾ (TA = 25°C, f = 1.0 MHz)

SYMBOL	PARAMETER	CONDITIONS	MAX.	UNIT
CIN	Input Capacitance	VIN=0V	6	pF
CDQ	Input/Output Capacitance	V/I=0V	8	pF

1. This parameter is guaranteed and not tested.

■ DC ELECTRICAL CHARACTERISTICS (TA = 0 to + 70°C)

PARAMETER NAME	PARAMETER	TEST CONDITIONS	MIN.	TYP. (1)	MAX.	UNITS	
V _{IL}	Guaranteed Input Low Voltage ⁽²⁾		-0.5	--	0.3V _{cc}	V	
V _{IH}	Guaranteed Input High Voltage ⁽²⁾		0.7V _{cc}	--	V _{cc} +0.2	V	
I _{IL}	Input Leakage Current	V _{cc} = Max, V _{IN} = 0V to V _{cc}	--	--	1	μA	
I _{OL}	Output Leakage Current	V _{cc} = Max, $\overline{CE1} = V_{IH}$, CE2 = V _L , or $\overline{OE} = V_{IH}$, V _{IO} = 0V to V _{cc}	--	--	1	μA	
V _{OL}	Output Low Voltage	V _{cc} = Max, I _{OL} = 1mA	--	--	0.4	V	
V _{OH}	Output High Voltage	V _{cc} = Min, I _{OH} = -0.5mA	1.6	--	--	V	
I _{CC}	Operating Power Supply Current	$\overline{CE1} = V_{L}$, or CE2 = V _{IH} , I _{OL} = 0mA, F = Fmax ⁽³⁾	V _{cc} =2.0V	--	--	15	mA
			V _{cc} =3.3V	--	--	20	
I _{CCSB}	Standby Power Supply Current	$\overline{CE1} = V_{IH}$, or CE2 = V _L , I _{OL} = 0mA, F = Fmax ⁽³⁾	V _{cc} =2.0V	--	--	0.5	mA
			V _{cc} =3.3V	--	--	1	
I _{CCSB1}	Power Down Supply Current	$\overline{CE1} \geq V_{cc}-0.2V$, CE2 ≤ 0.2V, V _{IN} ≥ V _{cc} -0.2V or V _{IN} ≤ 0.2V	V _{cc} =2.0V	--	0.01	0.3	μA
			V _{cc} =3.3V	--	0.02	0.5	

1. Typical characteristics are at TA = 25°C.

2. These are absolute values with respect to device ground and all overshoots due to system or tester noise are included.

3. Fmax = 1/t_{RC}.

■ DATA RETENTION CHARACTERISTICS (TA = 0 to + 70°C)

SYMBOL	PARAMETER	TEST CONDITIONS	MIN.	TYP. (1)	MAX.	UNITS
V _{DR}	V _{cc} for Data Retention	$\overline{CE1} \geq V_{cc} - 0.2V$, CE2 ≤ 0.2V, V _{IN} ≥ V _{cc} - 0.2V or V_{IN} ≤ 0.2V}	1.5	--	--	V
I _{CCDR}	Data Retention Current	$\overline{CE1} \geq V_{cc} - 0.2V$, CE2 ≤ 0.2V, V _{IN} ≥ V _{cc} - 0.2V or V_{IN} ≤ 0.2V}	--	0.01	0.2	μA
t _{CDR}	Chip Deselect to Data Retention Time	See Retention Waveform	0	--	--	ns
t _R	Operation Recovery Time		T _{RC} ⁽²⁾	--	--	ns

1. V_{cc} = 1.5V, T_A = + 25°C

2. t_{RC} = Read Cycle Time

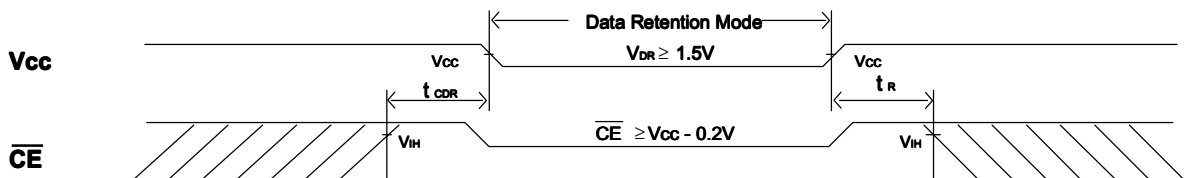
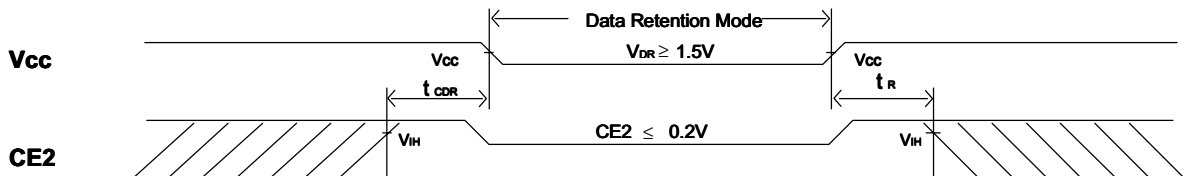
■ LOW V_{CC} DATA RETENTION WAVEFORM (1) ($\overline{CE1}$ Controlled)

■ LOW V_{CC} DATA RETENTION WAVEFORM (2) (CE2 Controlled)

■ AC TEST CONDITIONS

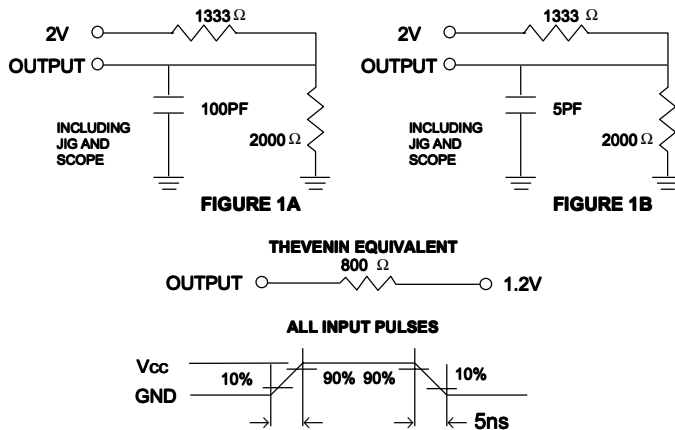
Input Pulse Levels	V _{CC} /0V
Input Rise and Fall Times	5ns
Input and Output Timing Reference Level	0.5V _{CC}

■ AC TEST LOADS AND WAVEFORMS

■ KEY TO SWITCHING WAVEFORMS

WAVEFORM	INPUTS	OUTPUTS
	MUST BE STEADY	MUST BE STEADY
	MAY CHANGE FROM H TO L	WILL BE CHANGE FROM H TO L
	MAY CHANGE FROM L TO H	WILL BE CHANGE FROM L TO H
	DON'T CARE: ANY CHANGE PERMITTED	CHANGE: STATE UNKNOWN
	DOES NOT APPLY	CENTER LINE IS HIGH IMPEDANCE "OFF" STATE

■ AC ELECTRICAL CHARACTERISTICS (over the operating range)
READ CYCLE

JEDEC PARAMETER NAME	PARAMETER NAME	DESCRIPTION	BS62UV1024-15			UNIT
			MIN.	TYP.	MAX.	
t _{AVAX}	t _{RC}	Read Cycle Time	150	--	--	ns
t _{AVQV}	t _{AA}	Address Access Time	--	--	150	ns
t _{E1LQV}	t _{ACS1}	Chip Select Access Time (CE1)	--	--	150	ns
t _{E2HOV}	t _{ACS2}	Chip Select Access Time (CE2)	--	--	150	ns
t _{GLQV}	t _{OE}	Output Enable to Output Valid	--	--	100	ns
t _{E1LQX}	t _{CLZ1}	Chip Select to Output Low Z (CE1)	10	--	--	ns
t _{E2HOX}	t _{CLZ2}	Chip Select to Output Low Z (CE2)	10	--	--	ns
t _{GLQX}	t _{OLZ}	Output Enable to Output in Low Z	10	--	--	ns
t _{E1HQZ}	t _{CHZ1}	Chip Deselect to Output in High Z (CE1)	0	--	40	ns
t _{E2HQZ}	t _{CHZ1}	Chip Deselect to Output in High Z (CE2)	0	--	40	ns
t _{GHQZ}	t _{OHZ}	Output Disable to Output in High Z	0	--	35	ns
t _{AXOX}	t _{OH}	Output Disable to Output Address Change	10	--	--	ns

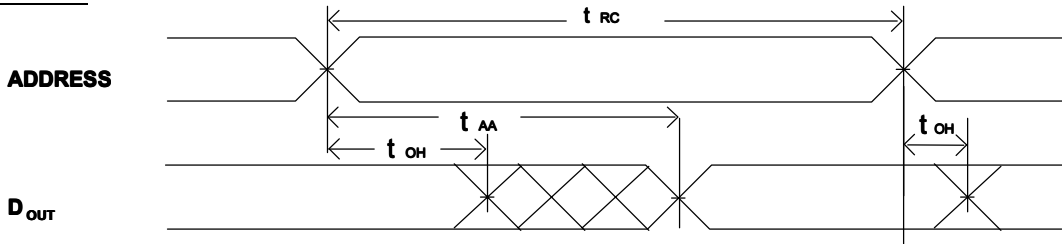
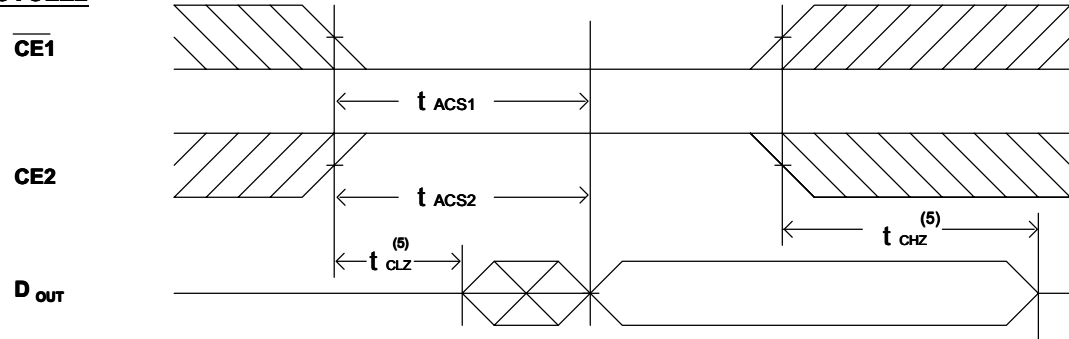
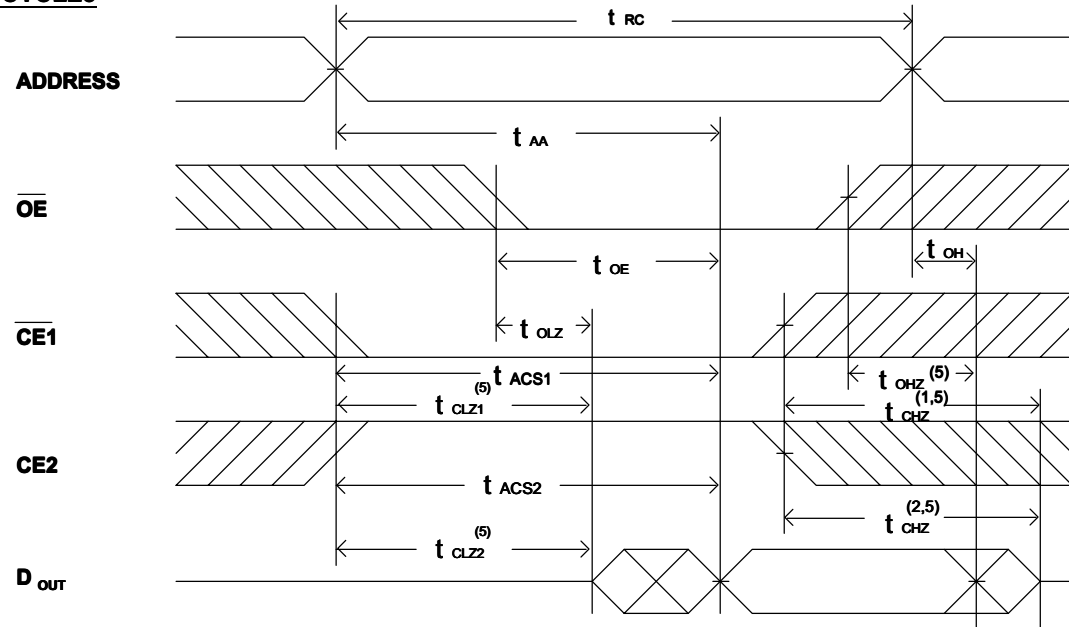
1. Typical characteristics are at V_{CC} = 2.0V, T_A = 25°C.

■ SWITCHING WAVEFORMS (READ CYCLE)
READ CYCLE1 (1,2,4)

READ CYCLE2 (1,3,4)

READ CYCLE3 (1,4)

NOTES:

1. WE is high for read Cycle.
2. Device is continuously selected when $\overline{CE1} = V_{IL}$ and $\overline{CE2} = V_{IH}$.
3. Address valid prior to or coincident with $\overline{CE1}$ transition low and/or $\overline{CE2}$ transition high.
4. $\overline{OE} = V_{IL}$.
5. Transition is measured $\pm 500\text{mV}$ from steady state with $C_L = 5\text{pF}$ as shown in Figure 1B. The parameter is guaranteed but not 100% tested.

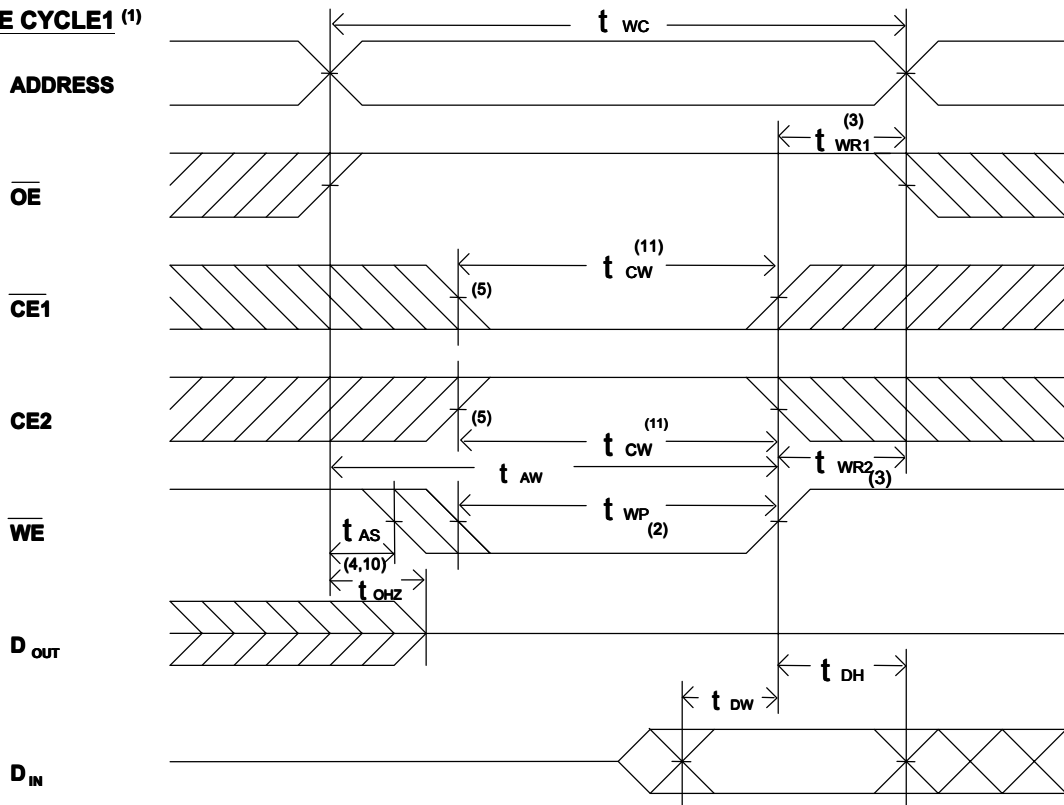
■ AC ELECTRICAL CHARACTERISTICS (over the operating range)
WRITE CYCLE

JEDEC PARAMETER NAME	PARAMETER NAME	DESCRIPTION	BS62UV1024-15			UNIT
			MIN.	TYP.	MAX.	
t_{AVAX}	t_{WC}	Write Cycle Time	150	--	--	ns
t_{E1LWH}	t_{CW}	Chip Select to End of Write	150	--	--	ns
t_{AVWL}	t_{AS}	Address Set up Time	0	--	--	ns
t_{AVWH}	t_{AW}	Address Valid to End of Write	150	--	--	ns
t_{WLWH}	t_{WP}	Write Pulse Width	80	--	--	ns
t_{WHAX}	t_{WR1}	Write Recovery Time (CE1, WE)	0	--	--	ns
t_{E2LAX}	t_{WR2}	Write Recovery Time (CE2)	0	--	--	ns
t_{WLOZ}	t_{WHZ}	Write to Output in High Z	--	--	40	ns
t_{DVWH}	t_{DW}	Data to Write Time Overlap	50	--	--	ns
t_{WHDX}	t_{DH}	Data Hold from Write Time	0	--	--	ns
t_{GHOZ}	t_{OHZ}	Output Disable to Output in High Z	0	--	40	ns
t_{WHQX}	t_{OW}	End of Write to Output Active	5	--	--	ns

1. Typical characteristics are at $V_{CC} = 2.0V$, $T_A = 25^\circ C$.

■ SWITCHING WAVEFORMS (WRITE CYCLE)
WRITE CYCLE1⁽¹⁾

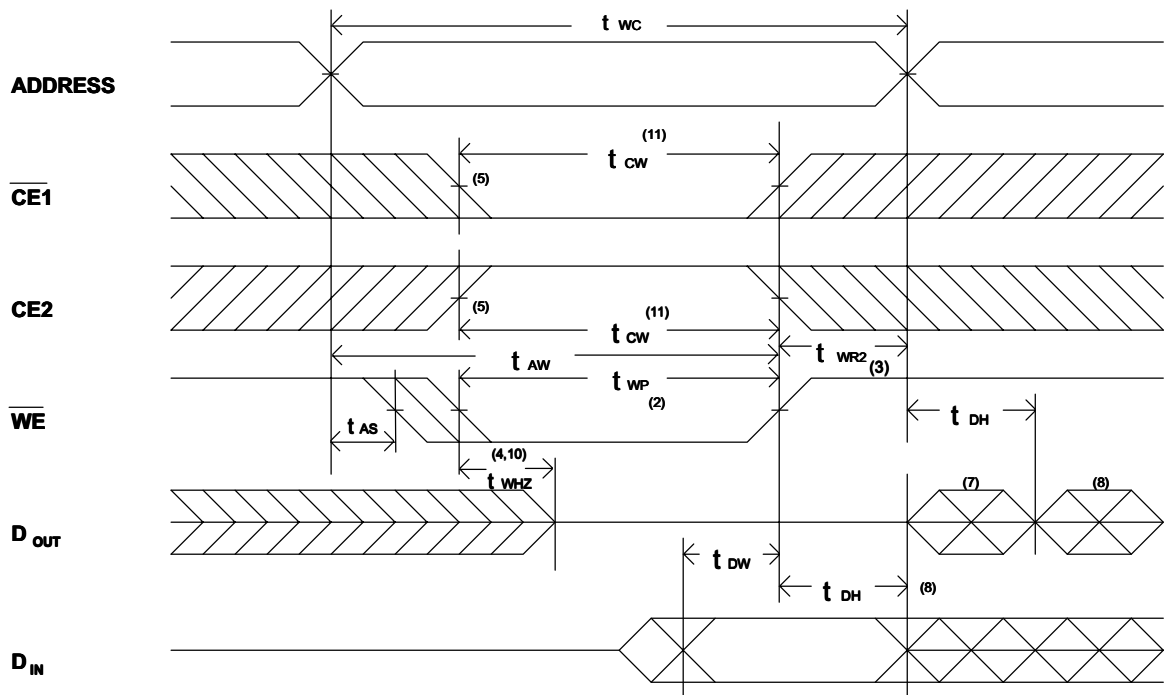
WRITE CYCLE2 (1,6)

NOTES:

1. \overline{WE} must be high during address transitions.
2. The internal write time of the memory is defined by the overlap of $\overline{CE1}$ and $\overline{CE2}$ active and \overline{WE} low. All signals must be active to initiate a write and any one signal can terminate a write by going inactive. The data input setup and hold timing should be referenced to the second transition edge of the signal that terminates the write.
3. TWR is measured from the earlier of $\overline{CE1}$ or \overline{WE} going high or $\overline{CE2}$ going low at the end of write cycle.
4. During this period, DQ pins are in the output state so that the input signals of opposite phase to the outputs must not be applied.
5. If the $\overline{CE1}$ low transition or the $\overline{CE2}$ high transition occurs simultaneously with the \overline{WE} low transitions or after the \overline{WE} transition, output remain in a high impedance state.
6. \overline{OE} is continuously low ($\overline{OE} = V_{IL}$).
7. D_{out} is the same phase of write data of this write cycle.
8. D_{out} is the read data of next address.
9. If $\overline{CE1}$ is low and $\overline{CE2}$ is high during this period, DQ pins are in the output state. Then the data input signals of opposite phase to the outputs must not be applied to them.
10. Transition is measured $\pm 500\text{mV}$ from steady state with $C_L = 5\text{pF}$ as shown in Figure 1B. The parameter is guaranteed but not 100% tested.
11. t_{cw} is measured from the later of $\overline{CE1}$ going low or $\overline{CE2}$ going high to the end of write.

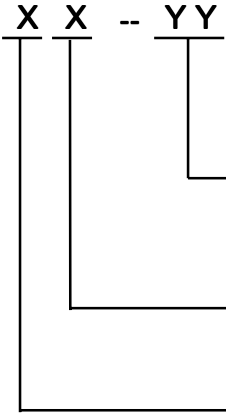
ORDERING INFORMATION

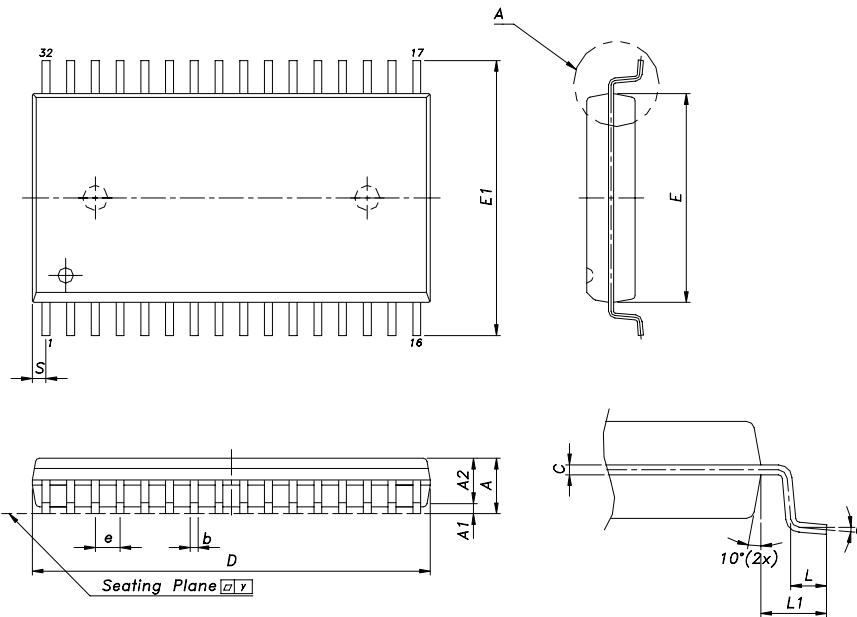
BS62UV1024 	SPEED 15: 150ns
	GRADE C: +0°C ~ +70°C I: -40°C ~ +85°C
	PACKAGE S: SOP T: TSOP (8mm x 20mm) ST: Small TSOP (8mm x 13.4mm)

PACKAGE DIMENSIONS

UNIT SYMBOL	INCH(BASE)	MM(REF.)
A	0.118(MAX)	2.997(MAX)
A1	0.004(MIN)	0.102(MIN)
A2	0.104±0.004	2.642±0.102
b	0.016(TYP)	0.406(TYP)
C	0.008(TYP)	0.203(TYP)
D	0.805±0.005	20.447±0.127
E	0.445±0.005	11.303±0.127
E1	0.556±0.012	14.122±0.305
e	0.050(TYP)	1.270(TYP)
L	0.031±0.008	0.787±0.203
L1	0.055±0.008	1.397±0.203
S	0.0275(TYP)	0.6985(TYP)
y	0.004(MAX)	0.102(MAX)
θ	0°-10°	0°-10°

DETAIL: A(SCALE 2/1)

SOP-32

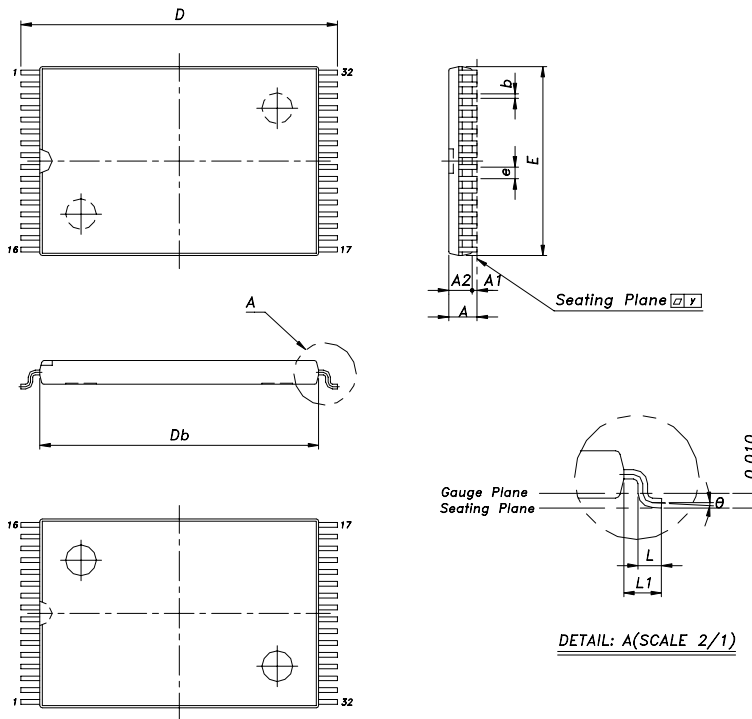
■ PACKAGE DIMENSIONS (continued)

UNIT SYMBOL	INCH(BASE)	MM(REF.)
A	0.047(MAX)	1.20(MAX)
A1	0.004±0.002	0.10±0.05
A2	0.039±0.002	1.00±0.05
b	0.008(TYP)	0.20(TYP)
C	0.006(TYP)	0.15(TYP)
Db	0.465±0.004	11.80±0.10
E	0.315±0.004	8.00±0.10
e	0.020(TYP)	0.50(TYP)
D	0.528±0.008	13.40±0.20
L	0.020±0.004	0.50±0.10
L1	0.0315±0.004	0.80±0.10
y	0.004(MAX)	0.102(MAX)
θ	0°-5°	0°-5°

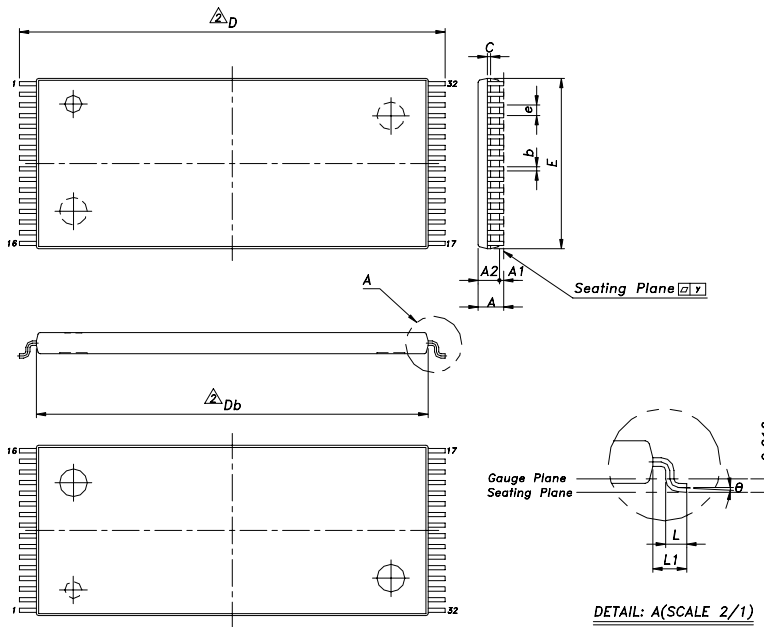
STSOP-32

UNIT SYMBOL	INCH(BASE)	MM(REF.)
A	0.047(MAX)	1.20(MAX)
A1	0.004±0.002	0.10±0.05
A2	0.039±0.002	1.00±0.05
b	0.008(TYP)	0.20(TYP)
C	0.006(TYP)	0.15(TYP)
Db	0.724±0.004	18.40±0.10
E	0.315±0.004	8.00±0.10
e	0.020(TYP)	0.50(TYP)
D	0.787±0.008	20.00±0.20
L1	0.0315±0.004	0.80±0.10
y	0.004(MAX)	0.102(MAX)
θ	0°-5°	0°-5°

(Option 1)

L	0.020±0.004	0.50±0.10
---	-------------	-----------

(Option 2)

L	0.024±0.004	0.60±0.10
---	-------------	-----------

TSOP-32

This page is left blank intentionally.

■ FEATURES

- Wide Vcc operation voltage : 2.4V ~ 5.5V
- Very low power consumption :
 - Vcc = 3.0V 20mA (Max.) write current
 - 1mA (Max.) read current
 - 0.02uA (Typ.) CMOS standby current
- Vcc = 5.0V 45mA (Max.) write current
- 2mA (Max.) read current
- 0.6uA (Typ.) CMOS standby current
- High speed access time :
 - 70 70ns (Max.)
- Input levels are CMOS-compatible
- Automatic power down when chip is deselected
- Three state outputs
- Fully static operation
- Data retention supply voltage as low as 1.5V
- Easy expansion with CE2, CE1, and OE options
- All I/O pins are 5V tolerant

■ DESCRIPTION

The BS62LV1024 is a high performance, very low power CMOS Static Random Access Memory organized as 131,072 words by 8 bits and operates from a wide range of 2.4V to 5.5V supply voltage. Advanced CMOS technology and circuit techniques provide both high speed and low power features with a typical CMOS standby current of 0.02uA and maximum access time of 70ns in 3V operation. Easy memory expansion is provided by an active LOW chip enable (CE1), an active HIGH chip enable (CE2), and active LOW output enable (OE) and three-state output drivers. The BS62LV1024 has an automatic power down feature, reducing the power consumption significantly when chip is deselected. The BS62LV1024 is available in the JEDEC standard 32 pin 525mil Plastic SOP, 8mmx13.4mm STSOP, and 8mmx20mm TSOP.

■ PRODUCT FAMILY

PRODUCT FAMILY	OPERATING TEMPERATURE	Vcc RANGE	SPEED (ns)	POWER DISSIPATION				PKG TYPE
				STANDBY (Iccsb1, Max)		Operating (Icc, Max)		
				Vcc= 5.0V	Vcc= 3.0V	Vcc= 5.0V	Vcc= 3.0V	
BS62LV1024SC	+0°C to +70°C	2.4V ~ 5.5V	70	3.0uA	0.5uA	45mA	20mA	SOP-32
BS62LV1024TC								TSOP-32
BS62LV1024STC								STSOP-32
BS62LV1024SI	-40°C to +85°C	2.4V ~ 5.5V	70	5.0uA	1.5uA	45mA	20mA	SOP-32
BS62LV1024TI								TSOP-32
BS62LV1024STI								STSOP-32

■ PIN CONFIGURATIONS

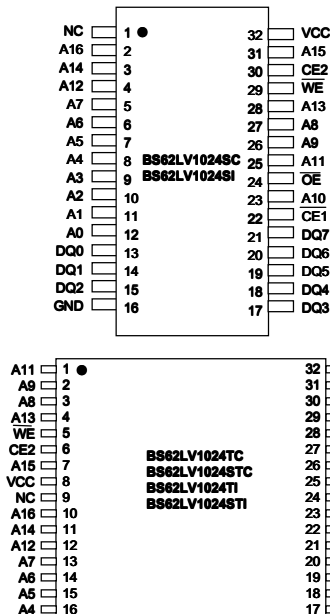

■ BLOCK DIAGRAM

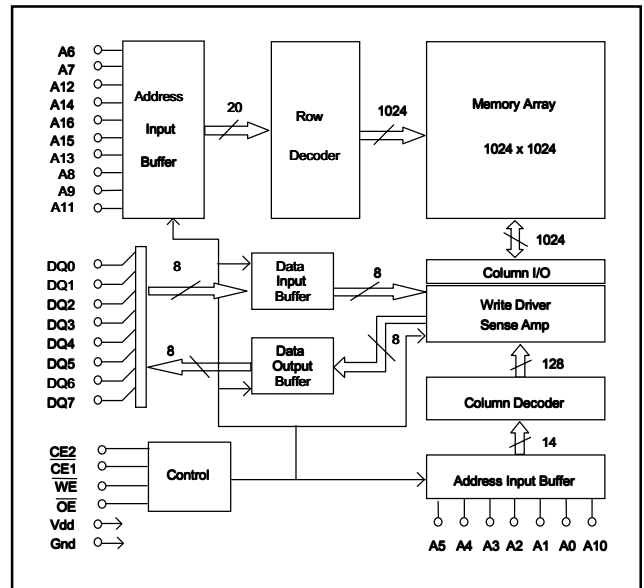

■ PIN DESCRIPTIONS

Name	Function
A0-A16 Address Input	These 17 address input select one of the 131,072 x 8-bit words in the RAM
$\overline{CE1}$ Chip Enable 1 Input $\overline{CE2}$ Chip Enable 2 Input	$\overline{CE1}$ is active LOW and $\overline{CE2}$ is active HIGH. Both chip enables must be active to read from or write to the device. If either chip enable is not active, the device is deselected and is in a standby power mode. The DQ pins will be in the high impedance state when the device is deselected.
\overline{WE} Write Enable Input	The write enable input is active LOW and controls read and write operations. With the chip selected, when \overline{WE} is HIGH and \overline{OE} is LOW, output data will be present on the DQ pins; when \overline{WE} is LOW, the data present on the DQ pins will be written into the selected memory location.
\overline{OE} Output Enable Input	The output enable input is active LOW. If the output enable is active while the chip is selected and the write enable is inactive, data will be present on the DQ pins and they will be enabled. The DQ pins will be in the high impedance state when \overline{OE} is inactive.
DQ0 – DQ7 Data Input/Output Ports	These 8 bi-directional ports are used to read data from or write data into the RAM.
Vcc	Power Supply
Gnd	Ground

■ TRUTH TABLE

MODE	\overline{WE}	$\overline{CE1}$	$\overline{CE2}$	\overline{OE}	I/O OPERATION	Vcc CURRENT
Not selected (Power Down)	X	H	X	X	High Z	I_{CCSB}, I_{CCSB1}
	X	X	L	X		
Output Disabled	H	L	H	H	High Z	I_{CC}
Read	H	L	H	L	DOUT	I_{CC}
Write	L	L	H	X	DIN	I_{CC}

■ ABSOLUTE MAXIMUM RATINGS⁽¹⁾

SYMBOL	PARAMETER	RATING	UNITS
VTERM	Terminal Voltage with Respect to GND	-0.5 to +6.0	V
TBIAS	Temperature Under Bias	-40 to +125	°C
TSTG	Storage Temperature	-60 to +150	°C
PT	Power Dissipation	1.0	W
IOUT	DC Output Current	20	mA

1. Stresses greater than those listed under ABSOLUTE MAXIMUM RATINGS may cause permanent damage to the device. This is a stress rating only and functional operation of the device at these or any other conditions above those indicated in the operational sections of this specification is not implied. Exposure to absolute maximum rating conditions for extended periods may affect reliability.

■ OPERATING RANGE

RANGE	AMBIENT TEMPERATURE	Vcc
Commercial	0°C to +70°C	2.4V ~ 5.5V
Industrial	-40°C to +70°C	2.4V ~ 5.5V

■ CAPACITANCE ⁽¹⁾ (TA = 25°C, f = 1.0 MHz)

SYMBOL	PARAMETER	CONDITIONS	MAX.	UNIT
CIN	Input Capacitance	VIN=0V	6	pF
CDQ	Input/Output Capacitance	V/I=0V	8	pF

1. This parameter is guaranteed and not tested.

■ DC ELECTRICAL CHARACTERISTICS (TA = 0 to + 70°C)

PARAMETER NAME	PARAMETER	TEST CONDITIONS	MIN.	TYP. (1)	MAX.	UNITS	
V _{IL}	Guaranteed Input Low Voltage ⁽²⁾		-0.5	--	0.3V _{cc}	V	
V _{IH}	Guaranteed Input High Voltage ⁽²⁾		0.7V _{cc}	--	V _{cc} +0.2	V	
I _{IL}	Input Leakage Current	V _{cc} = Max, V _{IN} = 0V to V _{cc}	--	--	1	uA	
I _{OL}	Output Leakage Current	V _{cc} = Max, $\overline{CE1} = V_{IH}$, CE2 = V _L , or $\overline{OE} = V_{IH}$, V _{IO} = 0V to V _{cc}	--	--	1	uA	
V _{OL}	Output Low Voltage	V _{cc} = Max, I _{OL} = 2mA	--	--	0.4	V	
V _{OH}	Output High Voltage	V _{cc} = Min, I _{OH} = -1mA	2.4	--	--	V	
I _{CC}	Operating Power Supply Current	$\overline{CE1} = V_{L}$, or CE2 = V _{IH} , I _{OL} = 0mA, F = Fmax ⁽³⁾	V _{cc} =3.0V	--	--	20	mA
			V _{cc} =5.0V	--	--	45	
I _{CCSB}	Standby Power Supply Current	$\overline{CE1} = V_{IH}$, or CE2 = V _L , I _{OL} = 0mA, F = Fmax ⁽³⁾	V _{cc} =3.0V	--	--	1	mA
			V _{cc} =5.0V	--	--	2	
I _{CCSB1}	Power Down Supply Current	$\overline{CE1} \geq V_{cc}-0.2V$, CE2 $\leq 0.2V$, V _{IN} $\geq V_{cc}-0.2V$ or V _{IN} $\leq 0.2V$	V _{cc} =3.0V	--	0.02	0.5	uA
			V _{cc} =5.0V	--	0.6	3	

1. Typical characteristics are at TA = 25°C.

2. These are absolute values with respect to device ground and all overshoots due to system or tester noise are included.

3. Fmax = 1/t_{RC}.

■ DATA RETENTION CHARACTERISTICS (TA = 0 to + 70°C)

SYMBOL	PARAMETER	TEST CONDITIONS	MIN.	TYP. (1)	MAX.	UNITS
V _{DR}	V _{cc} for Data Retention	$\overline{CE1} \geq V_{cc} - 0.2V$, CE2 $\leq 0.2V$, V _{IN} $\geq V_{cc} - 0.2V$ or V _{IN} $\leq 0.2V$	1.5	--	--	V
I _{CCDR}	Data Retention Current	$\overline{CE1} \geq V_{cc} - 0.2V$, CE2 $\leq 0.2V$, V _{IN} $\geq V_{cc} - 0.2V$ or V _{IN} $\leq 0.2V$	--	0.02	0.3	uA
t _{CDR}	Chip Deselect to Data Retention Time	See Retention Waveform	0	--	--	ns
t _R	Operation Recovery Time		T _{RC} ⁽²⁾	--	--	ns

1. V_{cc} = 1.5V, T_A = + 25°C

2. t_{RC} = Read Cycle Time

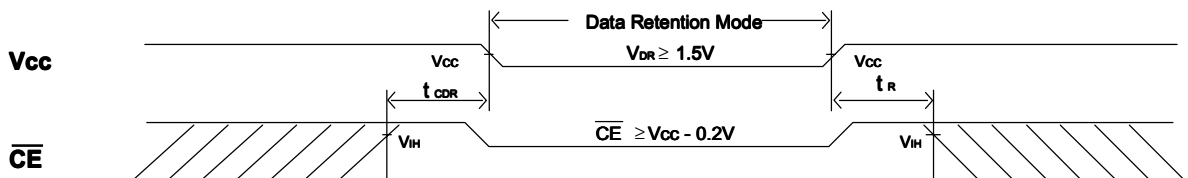
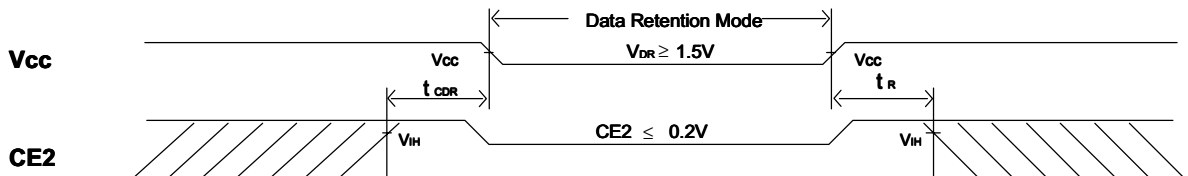
■ LOW V_{cc} DATA RETENTION WAVEFORM (1) ($\overline{CE1}$ Controlled)

■ LOW V_{cc} DATA RETENTION WAVEFORM (2) (CE2 Controlled)

■ AC TEST CONDITIONS

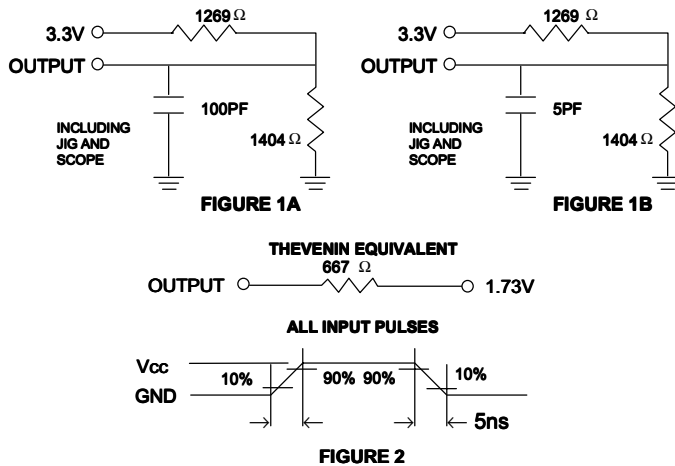
Input Pulse Levels	V _{cc} /0V
Input Rise and Fall Times	5ns
Input and Output Timing Reference Level	0.5V _{cc}

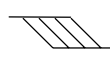
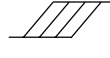
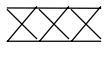
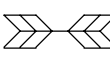
■ AC TEST LOADS AND WAVEFORMS

■ KEY TO SWITCHING WAVEFORMS

WAVEFORM	INPUTS	OUTPUTS
	MUST BE STEADY	MUST BE STEADY
	MAY CHANGE FROM H TO L	WILL BE CHANGE FROM H TO L
	MAY CHANGE FROM L TO H	WILL BE CHANGE FROM L TO H
	DON'T CARE: ANY CHANGE PERMITTED	CHANGE: STATE UNKNOWN
	DOES NOT APPLY	CENTER LINE IS HIGH IMPEDANCE "OFF" STATE

■ AC ELECTRICAL CHARACTERISTICS (over the operating range)
READ CYCLE

JEDEC PARAMETER NAME	PARAMETER NAME	DESCRIPTION	BS62LV1024-70			UNIT
			MIN.	TYP.	MAX.	
t _{AVAX}	t _{RC}	Read Cycle Time	70	--	--	ns
t _{AVQV}	t _{AA}	Address Access Time	--	--	70	ns
t _{E1LQV}	t _{ACS1}	Chip Select Access Time (CE1)	--	--	70	ns
t _{E2HOV}	t _{ACS2}	Chip Select Access Time (CE2)	--	--	70	ns
t _{GLQV}	t _{OE}	Output Enable to Output Valid	--	--	50	ns
t _{E1LQX}	t _{CLZ1}	Chip Select to Output Low Z (CE1)	10	--	--	ns
t _{E2HOX}	t _{CLZ2}	Chip Select to Output Low Z (CE2)	10	--	--	ns
t _{GLQX}	t _{OLZ}	Output Enable to Output in Low Z	10	--	--	ns
t _{E1HQZ}	t _{CHZ1}	Chip Deselect to Output in High Z (CE1)	0	--	40	ns
t _{E2HQZ}	t _{CHZ1}	Chip Deselect to Output in High Z (CE2)	0	--	40	ns
t _{GHQZ}	t _{OHZ}	Output Disable to Output in High Z	0	--	35	ns
t _{AXOX}	t _{OH}	Output Disable to Output Address Change	10	--	--	ns

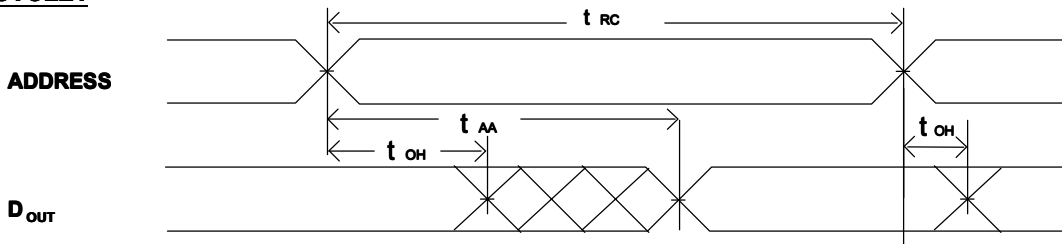
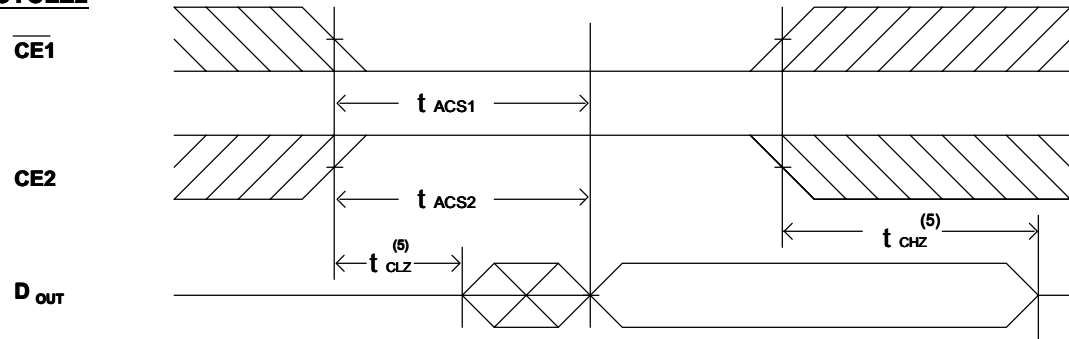
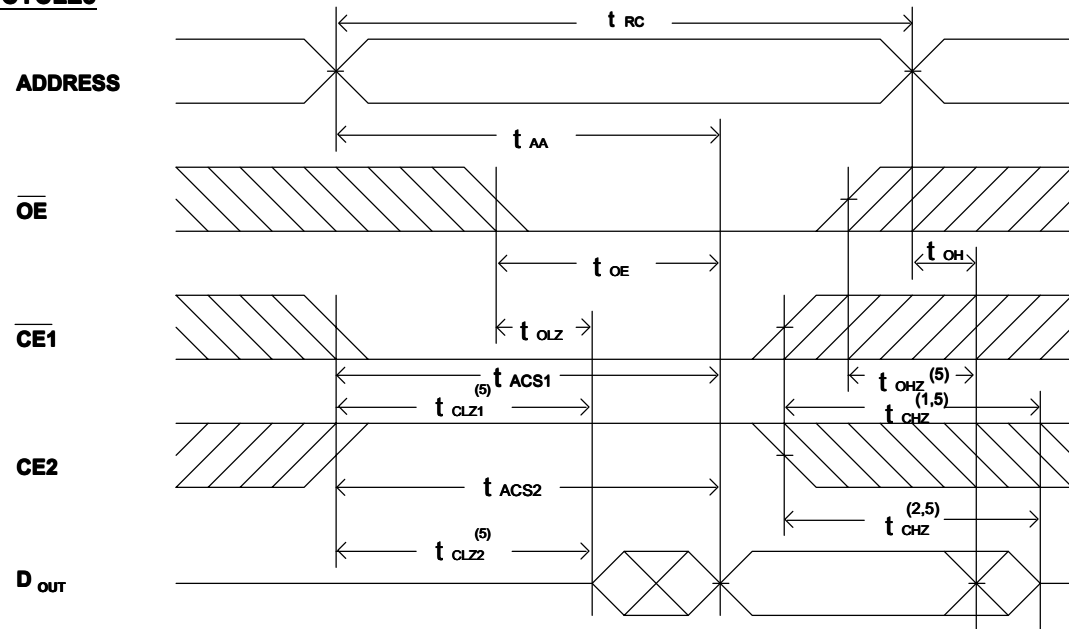
1. Typical characteristics are at V_{cc} = 3.3V, T_A = 25°C.

■ SWITCHING WAVEFORMS (READ CYCLE)
READ CYCLE1 (1,2,4)

READ CYCLE2 (1,3,4)

READ CYCLE3 (1,4)

NOTES:

1. WE is high for read Cycle.
2. Device is continuously selected when $\overline{CE1} = V_{IL}$ and $CE2 = V_{IH}$.
3. Address valid prior to or coincident with $\overline{CE1}$ transition low and/or $CE2$ transition high.
4. $\overline{OE} = V_{IL}$.
5. Transition is measured $\pm 500\text{mV}$ from steady state with $C_L = 5\text{pF}$ as shown in Figure 1B. The parameter is guaranteed but not 100% tested.

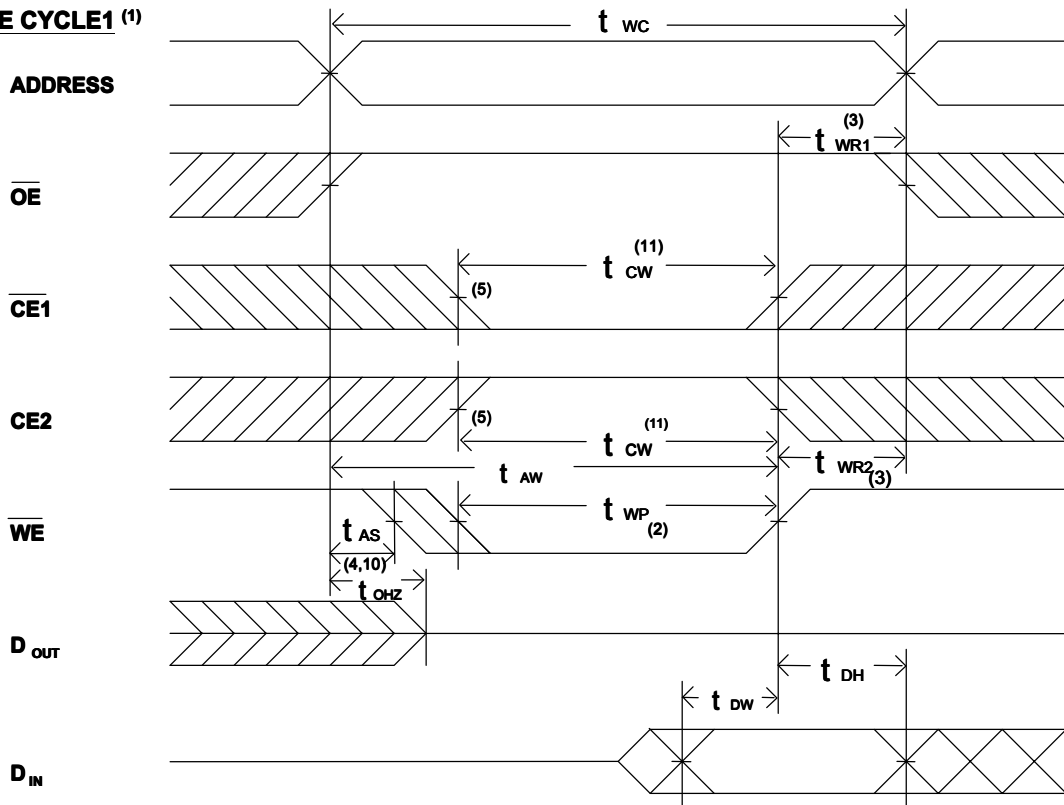
■ AC ELECTRICAL CHARACTERISTICS (over the operating range)
WRITE CYCLE

JEDEC PARAMETER NAME	PARAMETER NAME	DESCRIPTION	BS62LV1024-70			UNIT
			MIN.	TYP.	MAX.	
t_{AVAX}	t_{WC}	Write Cycle Time	70	--	--	ns
t_{E1LWH}	t_{CW}	Chip Select to End of Write	70	--	--	ns
t_{AVWL}	t_{AS}	Address Set up Time	0	--	--	ns
t_{AVWH}	t_{AW}	Address Valid to End of Write	70	--	--	ns
t_{WLWH}	t_{WP}	Write Pulse Width	50	--	--	ns
t_{WHAX}	t_{WR1}	Write Recovery Time (CE1, WE)	0	--	--	ns
t_{E2LAX}	t_{WR2}	Write Recovery Time (CE2)	0	--	--	ns
t_{WLOZ}	t_{WHZ}	Write to Output in High Z	0	--	30	ns
t_{DVWH}	t_{DW}	Data to Write Time Overlap	30	--	--	ns
t_{WHDX}	t_{DH}	Data Hold from Write Time	0	--	--	ns
t_{GHOZ}	t_{OHZ}	Output Disable to Output in High Z	0	--	30	ns
t_{WHQX}	t_{OW}	End of Write to Output Active	5	--	--	ns

1. Typical characteristics are at $V_{CC} = 3.3V$, $T_A = 25^\circ C$.

■ SWITCHING WAVEFORMS (WRITE CYCLE)
WRITE CYCLE1⁽¹⁾

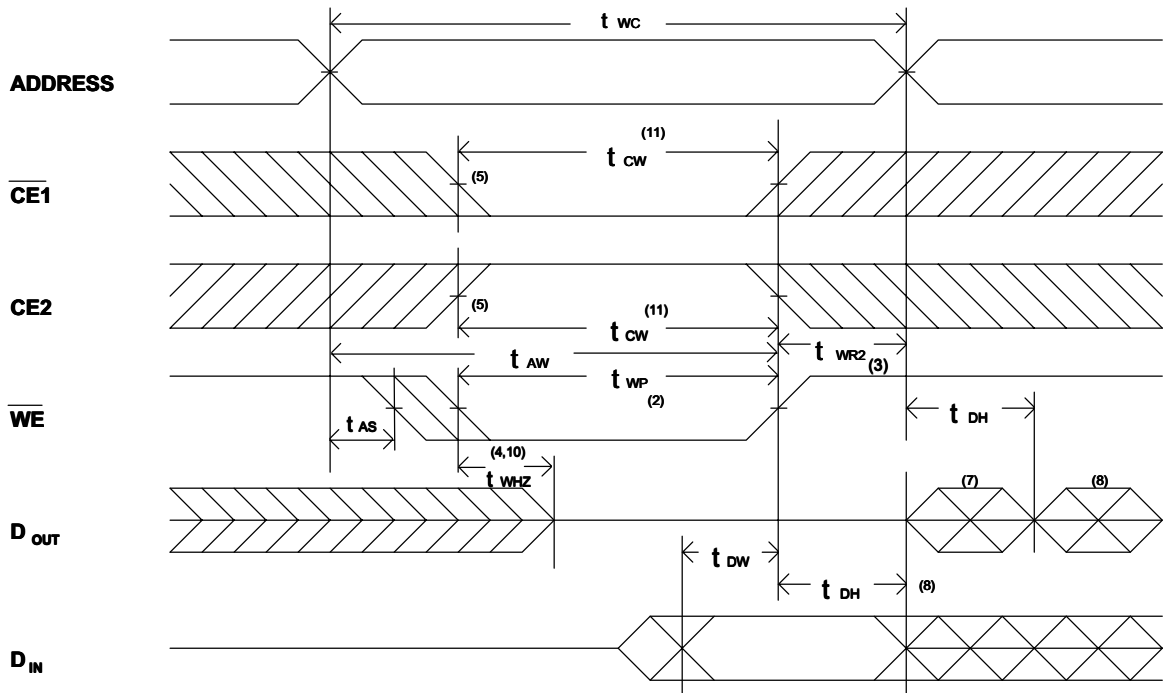
WRITE CYCLE2 (1,6)

NOTES:

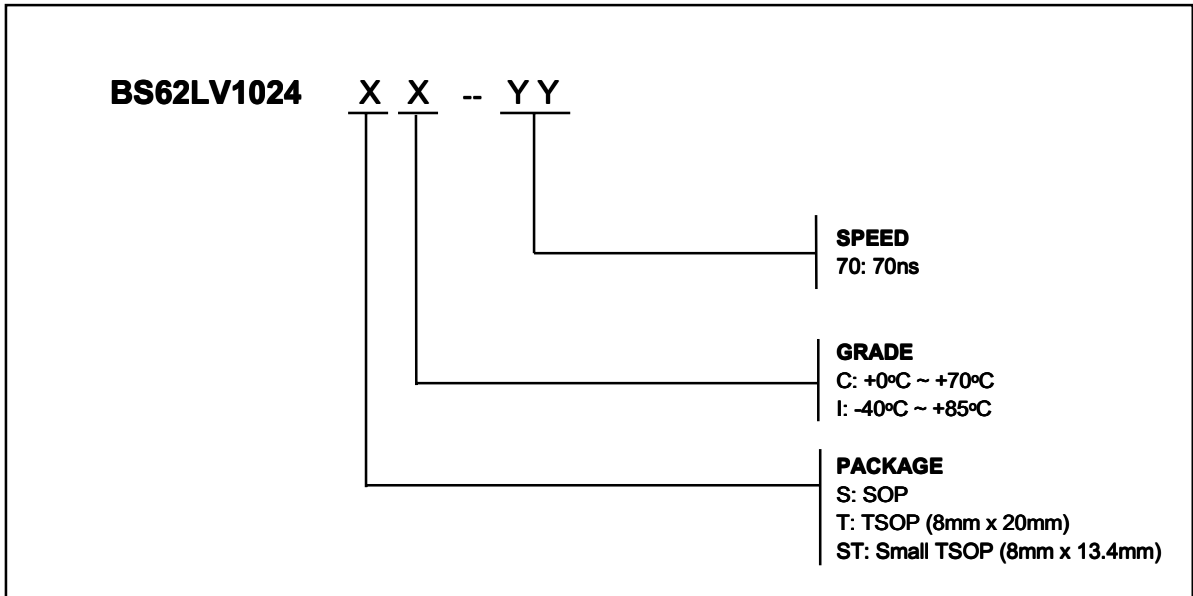
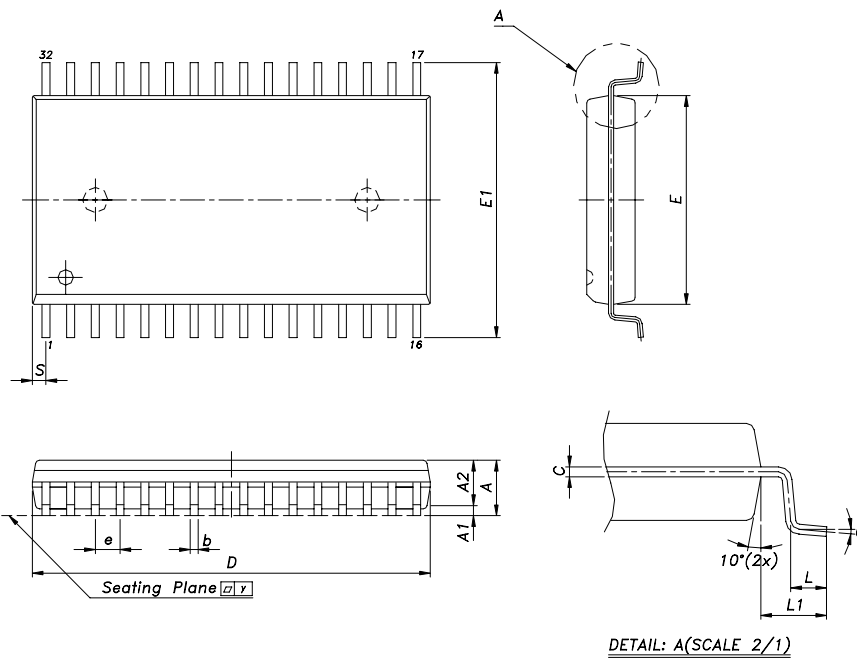
1. \overline{WE} must be high during address transitions.
2. The internal write time of the memory is defined by the overlap of $\overline{CE1}$ and $\overline{CE2}$ active and \overline{WE} low. All signals must be active to initiate a write and any one signal can terminate a write by going inactive. The data input setup and hold timing should be referenced to the second transition edge of the signal that terminates the write.
3. TWR is measured from the earlier of $\overline{CE1}$ or \overline{WE} going high or $\overline{CE2}$ going low at the end of write cycle.
4. During this period, DQ pins are in the output state so that the input signals of opposite phase to the outputs must not be applied.
5. If the $\overline{CE1}$ low transition or the $\overline{CE2}$ high transition occurs simultaneously with the \overline{WE} low transitions or after the \overline{WE} transition, output remain in a high impedance state.
6. \overline{OE} is continuously low ($\overline{OE} = V_{IL}$).
7. D_{out} is the same phase of write data of this write cycle.
8. D_{out} is the read data of next address.
9. If $\overline{CE1}$ is low and $\overline{CE2}$ is high during this period, DQ pins are in the output state. Then the data input signals of opposite phase to the outputs must not be applied to them.
10. Transition is measured $\pm 500mV$ from steady state with $C_L = 5pF$ as shown in Figure 1B. The parameter is guaranteed but not 100% tested.
11. t_{cw} is measured from the later of $\overline{CE1}$ going low or $\overline{CE2}$ going high to the end of write.

ORDERING INFORMATION

PACKAGE DIMENSIONS

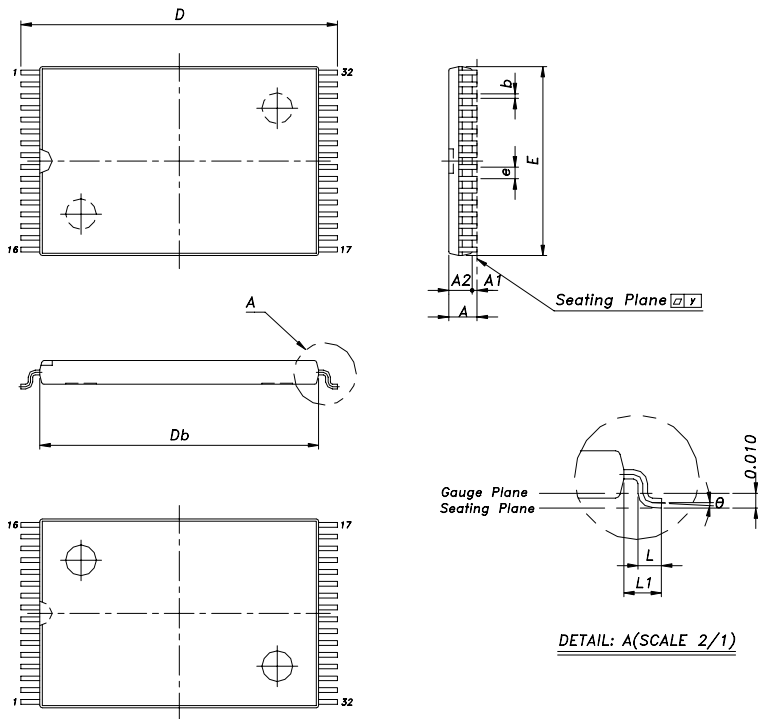
UNIT SYMBOL	INCH(BASE)	MM(REF.)
A	0.118(MAX)	2.997(MAX)
A1	0.004(MIN)	0.102(MIN)
A2	0.104±0.004	2.642±0.102
b	0.016(TYP)	0.406(TYP)
c	0.008(TYP)	0.203(TYP)
D	0.805±0.005	20.447±0.127
E	0.445±0.005	11.303±0.127
E1	0.556±0.012	14.122±0.305
e	0.050(TYP)	1.270(TYP)
L	0.031±0.008	0.787±0.203
L1	0.055±0.008	1.397±0.203
S	0.0275(TYP)	0.6985(TYP)
y	0.004(MAX)	0.102(MAX)
θ	0°-10°	0°-10°

SOP-32

■ PACKAGE DIMENSIONS (continued)

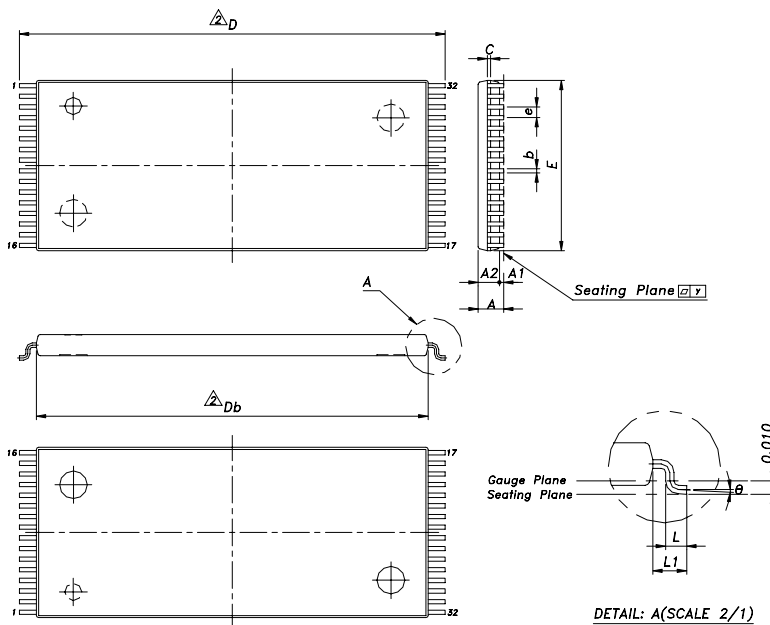
UNIT SYMBOL	INCH(BASE)	MM(REF.)
A	0.047(MAX)	1.20(MAX)
A1	0.004±0.002	0.10±0.05
A2	0.039±0.002	1.00±0.05
b	0.008(TYP)	0.20(TYP)
C	0.006(TYP)	0.15(TYP)
Db	0.465±0.004	11.80±0.10
E	0.315±0.004	8.00±0.10
e	0.020(TYP)	0.50(TYP)
D	0.528±0.008	13.40±0.20
L	0.020±0.004	0.50±0.10
L1	0.0315±0.004	0.80±0.10
y	0.004(MAX)	0.102(MAX)
θ	0°-5°	0°-5°

STSOP-32

UNIT SYMBOL	INCH(BASE)	MM(REF.)
A	0.047(MAX)	1.20(MAX)
A1	0.004±0.002	0.10±0.05
A2	0.039±0.002	1.00±0.05
b	0.008(TYP)	0.20(TYP)
C	0.006(TYP)	0.15(TYP)
Db	0.724±0.004	18.40±0.10
E	0.315±0.004	8.00±0.10
e	0.020(TYP)	0.50(TYP)
D	0.787±0.008	20.00±0.20
L1	0.0315±0.004	0.80±0.10
y	0.004(MAX)	0.102(MAX)
θ	0°-5°	0°-5°

(Option 1)

L	0.020±0.004	0.50±0.10
---	-------------	-----------

(Option 2)

L	0.024±0.004	0.60±0.10
---	-------------	-----------

TSOP-32

This page is left blank intentionally.