

DIGITAL CLOCK

_____ *Project Report*

Guide: Smt. Sriparna Bhattacharya

Performed by:

*Sujoy Mukherjee
(Heritage Institute of Technology)*

*Tridip Paul
(Heritage Institute of Technology)*

*Partha Rahaman
(University Institute of Technology)*

Digital Clock

----- A Report

Acknowledgement

Our project on “Digital Clock” is mainly concerned with designing of the circuit and implementing it on the Vero board. All this has been possible for the generous effort of Prof. B.B.Paira, Director –Heritage institute of Technology who has arranged the course on *Development and Testing Electronic Systems* in collaboration with Electronics Test and Development Centre who have also responded to his appeal. Our heartiest thanks go to Mrs. S. Bhattacharya under whose guidance the entire project was being conducted. We are grateful to Mr. D. Chattopadhyay, Mrs. D.Ganguly, Ms. Manjushree, Ms. Debjani, Ms.Rupa, Mr.Amitava who have helped us in various manners. Besides we would like to thank to the faculty of the Centre as mentioned for their visit to inspect our progress.

Sujoy Mukherjee
(Heritage Institute)
Tridip Paul
(Heritage Institute)
Partha Rahaman
(University Institute)

Abstract

The clock consists of three sections—seconds, minutes, hours and after reading the time 23 hours 59 mins 59 secs it resets back to 00.00.00, better referred to as the 0th hour.

Keywords

- a. Using IC 7490, 7447 & 5001.
- b. Designing Sequential Circuit (Counter designing with MOD-2 MOD-5 –the two most basic blocks of IC 7490).

Introduction

We know that 60 seconds equal to 1 minute and 60 minutes equal to 1 hour. Hence the minute section is driven by second section and hour section by the minute section. Each of the minute and second section has been designed to give a count from 00 to 59 after which it resets to 00. and the hour section to give a count from 00 to 23 hours after which it resets to 00. For each cycle of 00 to 59 in second section the minute section increases its count by 1. Similarly for each cycle of 00 to 59 in minute section the hour section increases its count by 1. In this way when the clock reaches 23hrs. 59mins. 59secs. each of the section resets to 00 giving us a display 00.00.00 popularly known as the 0th hour.

*

*

Now, without wasting any time we straightaway move into the discussion with our project with emphasis on different sections considering the modules.

Module Structure

The entire project has been divided into four modules. They are as follows:

❶ Second section

- ❑ Using two counter ICs (IC 7490) in such a way that this portion produces output from 00 to 59 continuously with a frequency of 1 Hz (1pps).
- ❑ Using Driver IC (IC 7447) and seven-segment display (IC 5001) to display the counts. Both the ICs are of common anode type.
- ❑ Checking the output of the circuit.

❷ Minute section

- ❑ Repeating the same circuit as that of the second section, but here the output should count from 00 to 59 with a frequency of 1Hz.for 1 ppm.
- ❑ Checking the output.

❸ Hour section

- ❑ Designing the circuit in such a way so that the output resets to 00 automatically displaying 23.59.59
- ❑ Here the counting proceeds with a frequency of one pulse per hour.
- ❑ Checking the output.

❹

- ❑ Assembling the three sections together.
- ❑ Checking the output the final circuit.

Block Diagram

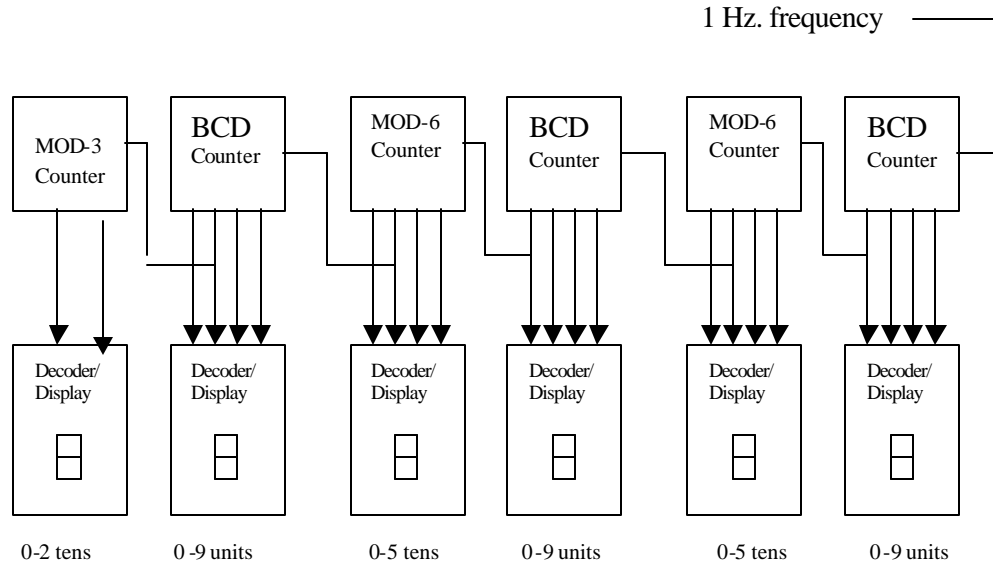

Fig.1

Basic Concept

It is evident from the block diagram that for each of Second and Minute section we require a Decade Counter for the unit's place and a Mod 6 counter for the ten's place. For the second and minute sections the situation is identical with the unit's place counting from 0-9-0 and repeats whereas the ten's place counts from 0-5-0 and repeats. For the Hour section we require the counter for the unit's place to count 0-3-0 and for the ten's place it counts 0-2-0 and repeats. The circuit could have been easily designed with an IC 7476 i.e. a dual JK Flip-Flop but to maintain parity between the components used we stick to the basics by using IC- 7490 (details mentioned later).

Components used

Material	Quantity
□ IC 7490 (14 pins)	----- 6(2 for each section)
□ IC 7447 (16 pins)	----- 6(2 for each section)
□ 7-segment display (IC 5501)	----- 6(2 for each section)
□ Resistances 100	----- 44(all total)
	8 for unit's place (7 for seconds section)
	7 for ten's place (in all the sections)

N.B.: IC 7447 and 5501 are of common anode type.

Component Description

IC 7490

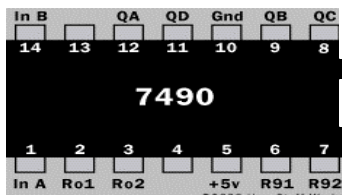

Fig.2

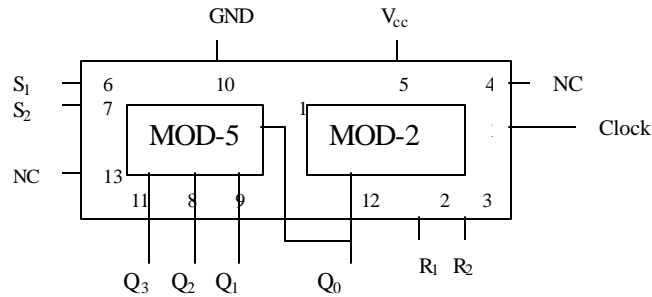

Fig.2a

The IC 7490 is a 4-bit, ripple-type Decade counter. The device consists of four master-slave flip-flops internally connected to provide a divide-by-two section and a divide-by-five section. Each section has a separate clock input to initiate state changes of the counter on the High-to-Low clock transition. State changes of the Q outputs do not occur simultaneously because of internal ripple delays. Therefore decoded output signals are subject to decoding spikes and should not be used for clocks or strobes.

A gated AND asynchronous Master Reset ($MR_1 - MR_2$) is provided which overrides both clocks and resets (clears) all the flip-flops. Also provided is a gated AND asynchronous Master Set (MS_1-MS_2), which overrides the clock and the MR inputs, setting the output to nine (HLLH).

N.B.: In the fig. Master Reset and Master Set have been denoted by R_1, R_2 & S_1, S_2 respectively.

IC 7447 & 5501 (Seven-segment Display)

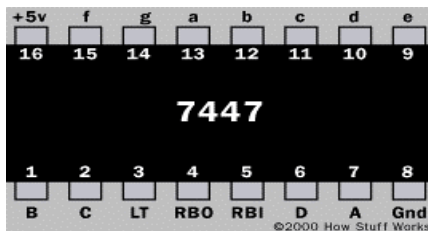

Fig.3

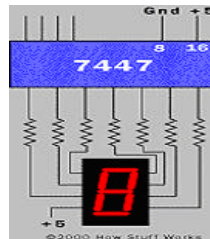

Fig.4

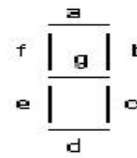

Fig.5

According to the Pin configuration:

LT=Lamp Test → After doing every connection between the chip and the segment if this terminal (LT) is grounded then all segment will glow. In the working mode LT should always be High.

BI/RBO=Blanking input/Ripple blanking Output → when this terminal is grounded the display will be blank immediately.

RBI=Ripple Blanking input. When this terminal is grounded and the input code is set for zero display then the display will be blank immediately and zero will come out independent of LT.

In the IC a, b, c, d, e, f, g are the pins which are connected to the 5501 seven-segment display and the parts which blink for these connections are shown above.

MODULE Details

Seconds Section:

Since the basic concept regarding the counting of the seconds has been discussed we are now going to design the circuit. Since the count is from 00-59 we would design a MOD-60 counter by cascading a MOD-10/ Decade Counter and a MOD-6 Counter. The IC-7490 is a Decade Counter with two parts (internal structure): MOD-2 and MOD-5 Counter. So we would design the MOD-6 counter basically from a Decade Counter.

Realization of MOD-6 from IC-7490:

----- MODE Selection Function Table-----

RESET/SET INPUTS				OUTPUTS			
MR ₁	MR ₂	MS ₁	MS ₂	Q ₀	Q ₁	Q ₂	Q ₃
H	H	L	X	L	L	L	L
H	H	X	L	L	L	L	L
X	X	H	H	H	L	L	H
L	X	L	X			COUNT	
X	L	X	L			COUNT	
L	X	X	L			COUNT	
H	L	L	X			COUNT	

Table 1.

Using the reset pins as shown in Fig.2a we can design any MOD-K Counter by the internal components --Mod-2 and Mod-5 counters of a particular IC-7490.

A Clock of 1 Hz. Frequency is supplied to the unit's part of the second's section at a rate of 1 pulse per second (1pps). On the other hand the ten's part is getting a negative-edge trigger which is the clock for the ten's part. The clock pulse is applied from Q₃. The reason being it resets after nine represented in binary as:

$$\begin{array}{cccc}
 Q_3 & Q_2 & Q_1 & Q_0 \\
 9 = & 1 & 0 & 0 & 1
 \end{array}$$

The output of this part is solely responsible for driving the minute section i.e. acting as a clock for the minute section. From the truth table (Table 1.) we see for MR₁ & MR₂ both equal to 1 the clock is reset and the output is zero.

In the ten's part the count resets to 0 after 5.

Representing '6' in binary form we have $6 = 0 \begin{array}{cccc} Q_3 & Q_2 & Q_1 & Q_0 \\ & 1 & 1 & 0 \end{array}$

Taking the high inputs Q₂ Q₁ we apply to the reset pins to solve our purpose.

Circuit Diagram

The Circuit that has been exactly designed is shown here.

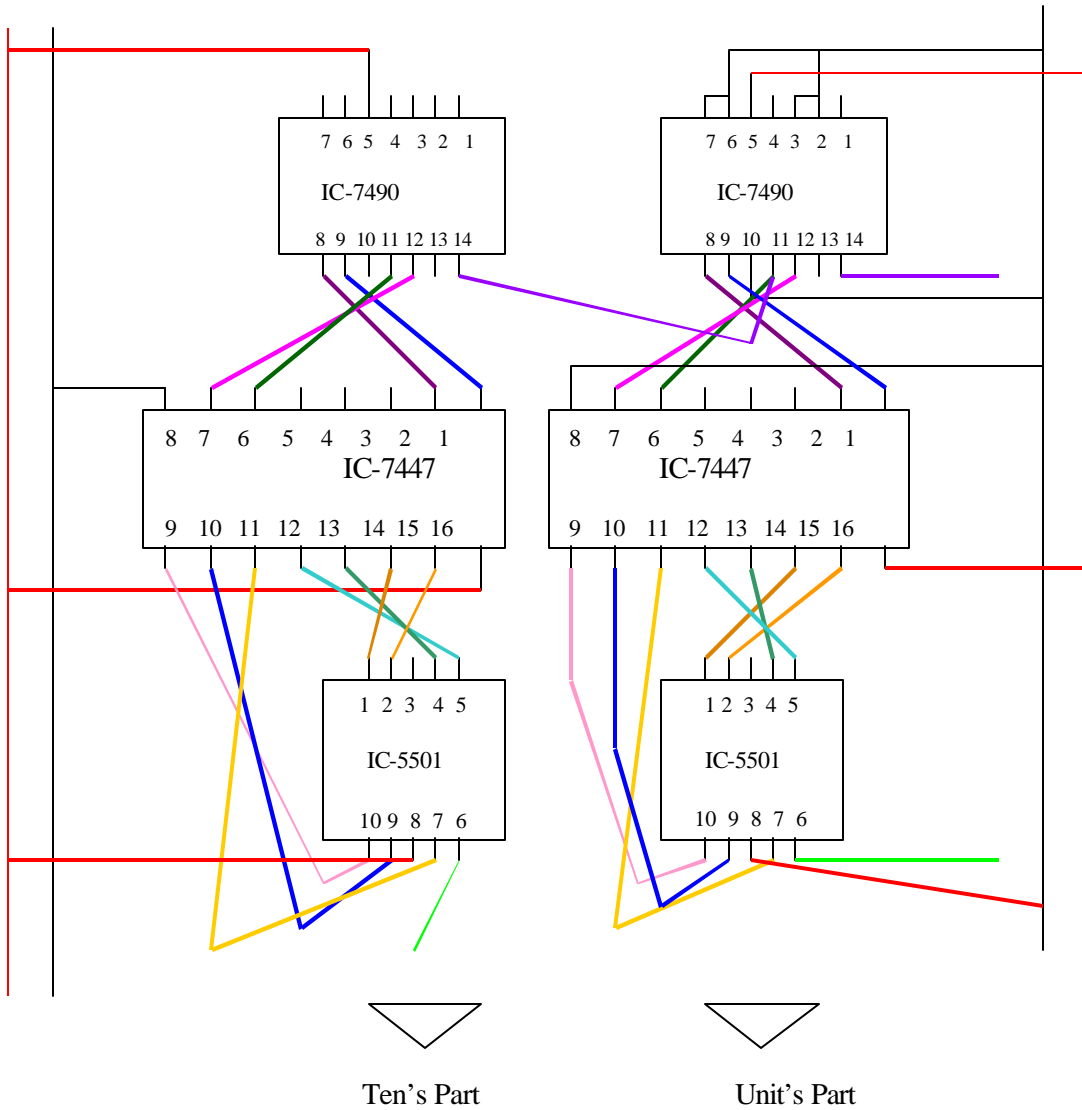

Fig.6

N.B.: We have used 100 resistances between IC-7447 and IC-5501(not shown in the Fig.6).

— V_{cc} — Gnd. — To glow the dot of IC-5501 we connect it to Gnd through a resistance otherwise no connection is made.

Minute Section

The Minute section is nothing but an exact replica of the second's section as the theory and implementation is the same with one major exception i.e. the clock from the second's section is applied to the unit's place of the minute's section at a rate of 1 pulse per minute (1ppm).

Hour Section

For the Hour section we have an altogether a different circuit design where the unit's place counts from 0-9 twice and 0-2 once in this sequence. Here the counting takes place from 00- 23 and resets back to 00. For the unit's place we use a Decade counter as done previously. And for the ten's place we have designed a MOD-3 counter simply using the MOD-5 counter part of IC-7490. We, now, check the condition for which the hour section should reset.

	Tens	Units		
for	0	4	⇒	
or	1	4		the clock is not reset to '0'
But for	2	4	⇒	the clock is reset to '0'

Thus if the two reset pins of the two counters are connected with each other (i.e. MR_1 & MR_2) and MR_1 is again connected with Q_2 of the unit's place and MR_2 is connected with Q_1 of the ten's place then the clock is reset after 23 to 00.

Since binary representation of,

	Q ₃	Q ₂	Q ₁	Q ₀
2=	0	0	<u>1</u>	0
4=	0	<u>1</u>	0	0

Thus Q_1 of the ten's place and Q_2 of the unit's place reset each other. Since $MR_1 = Q_2$ of the unit's place =1 and $MR_2 = Q_1$ of the ten's place =1. Since both MR_1 & MR_2 are high they need to reset the clock to 0 after 23.59.59 to 00.00.00, which is known as the 0th hour.

For the hour section the clock drives its unit's place from Q_2 of the ten's place of the minute section and the clock pulse is produced at the rate of 1 pulse per hour, i.e. 1pph.

In the following page we have the circuit for the hour section with the internal circuitry connections shown.

Circuit Diagram

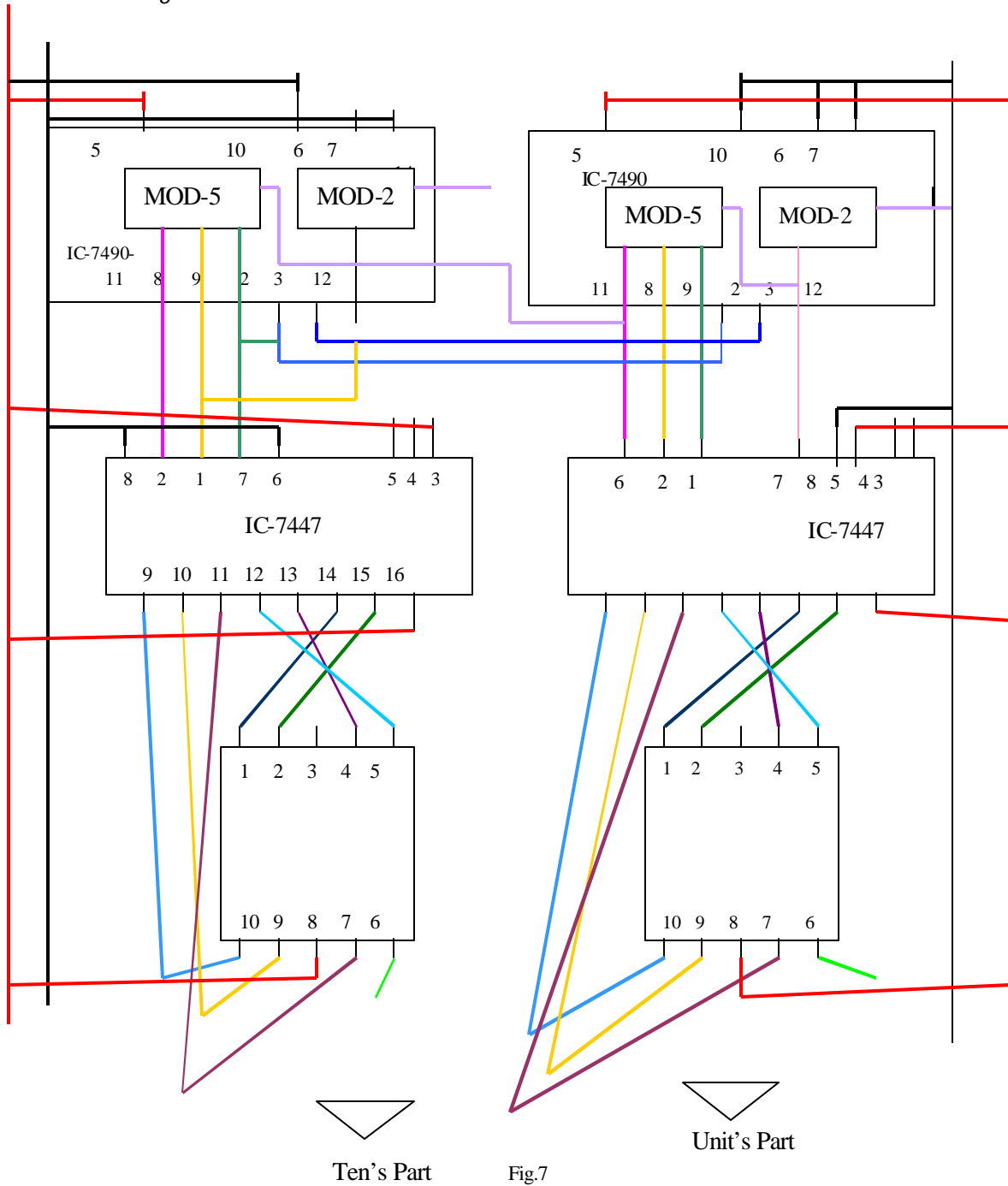

N.B.: In this circuit we have not used the conventional pin configured ICs but a circuit denoting proper connections to make things easier and simpler to understand. The convention used for Fig. 6 is maintained here also.

Assembling the three sections

Now that the circuit designing part is more or less complete the hard work is over and we assemble the three sections (seconds, minute and hour) to get the **“Digital Clock”**. With the supply connected we operate the clock to check the output.

The clock was found to operate smoothly.

Conclusion

The Circuit was purely designed with the basic knowledge on sequential circuit designing and with the components provided by the authority. The Clock is expected to operate normally with desired accuracy.
